

PE-515 *Pure Embedded 10/100/1000 5 Port Industrial Ethernet Switch*

1 Overview

The perfect fit for any stable, future-proof system, even where space is limited

- Stability of design guaranteed compatibility until at least 2035 (min. 10 years)
- Compact form – smaller than a standard business card (55x55mm)
- Seamless integration with design software - logical placements and fixed distances
- 3D CAD files
- Board-to-board and board-to-cable connection
- LEDs visible in all orientations – option to route through fibre

1.1 Functionality and Features

- 5 port 10/100/1000Mbps switch (10BASE-T/100BASE-TX/1000BASE-T)
- 3.3 to 5 VDC Input
- Reverse Polarity Protected
- Transient Voltage Protected
- 1500V magnetic isolation between ports
- Auto MDI/MDIX
- Power and link indicators for all ports visible from all angles
- Board-to-board and wire-to-board compatible
- IDC style connectors (Compatible with board-to-board and wire-to-board connections)
- IEEE 802.3x flow control
- Non-blocking layer 2 operation
- Extremely compact 55x55mm board size
- Full 2D and 3D CAD files available

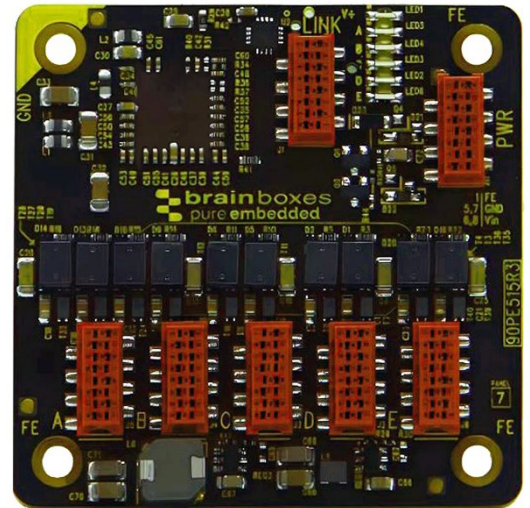

Figure 1, PE-515

[Pure Embedded Design Tool Kit](#) (resources include: Mechanical outline, 2D footprint, 3D model)

1.2 Specification

Table 1, General Information

Voltage Input	3.3 to 5 VDC
Maximum Power Consumption ¹	3.3W
Standard Compliance	IEEE 802.3ab FCC Part 15 Class A EN 55033 Class A
Operating Temperature	-40°C to +80°C / -40°F to +176°F
Storage Temperature	-40°C to +80°C / -40°F to +176°F
Size	55 x 55 x 16 mm / 2.17 x 2.17 x 0.629 in
Weight	0.025kg / 0.881oz
GTIN (barcode)	837324005325

¹ For further detail check Manual Section 10
V1.0 (2025-01-29)

1.3 Connectors

The Board contains Seven 8-way female IDC-style connectors for link and power.

Table 2, Male Header Compatibility

Type	Manufacturer	Part Number
SMD	Würth	690357280876
	TE	338728-8
THT	Würth	690357100872
	TE	215464-8
Board to Wire	Würth	690157000872
	TE	215083-8
		338095-8

Table 3, Connector Wiring Guide

Connector/PIN	1	2	3	4	5	6	7	8
Port A-E (RJ45 Pin)	RXD – Orange (Pin 6)	RXD + Orange/White (Pin 3)	TXD – Green (Pin 2)	TXD + Green/White (Pin 1)	N/A	N/A	N/A	N/A
Port A-E (RJ45 Pin)	RXD – Orange (Pin 6)	RXD + Orange/White (Pin 3)	TXD – Green (Pin 2)	TXD + Green/White (Pin 1)	TXD + Green/White (Pin 4)	TXD + Green/White (Pin 5)	TXD + Green/White (Pin 8)	TXD + Green/White (Pin 7)
LINK	Port A	Port B	Port C	Port D	Port E	LED Power	GND	-
PWR	FE	-	-	-	GND	VIN	GND	VIN

2 Ordering

Table 4, Ordering Information

Product Code	Description
PE-405	Pure Embedded 10/100 5 Port Industrial Ethernet Eval Kit
PE-505	Pure Embedded 10/100 5 Port Industrial Ethernet Switch
PE-205	Pure Embedded Dual Output Industrial Power Supply
PE-515	Pure Embedded 1G 5 Port Industrial Ethernet Switch
PE-415	Pure Embedded 1G 5 Port Industrial Ethernet Evaluation Kit

3 Changelog

Table 5, Changelog

Date	Revision	Author	Approval	Notes
11/2024	0.9	BH/JM	AM	Internal Release
01/2025	1.0	HR	AM	Marketing Review and external release

Please check <https://www.brainboxes.com/product/pure-embedded/pe-515> for the most recent datasheet revision

4 Table of Contents

1	Overview	1
1.1	Functionality and Features	1
1.2	Specification	1
1.3	Connectors	2
2	Ordering	2
3	Changelog	2
4	Table of Contents	3
5	List of Tables	3
6	List of Figures	3
7	PE-415 Embedded Eval Kit	4
8	Design Guide	5
8.1	Connectors and pinouts	5
8.1.1	Ethernet Header (8 Pin)	5
8.1.2	Link LED Header (8 Pin)	6
8.1.3	Mounting Holes	6
8.2	Mechanical Outline	7
8.3	3D Step File	7
8.4	Recommended Footprint	8
8.5	Routing	8
9	Troubleshooting	9
9.1	Device Markings	9
10	Operating Conditions	10
10.1	Absolute Maximum Ratings	10
10.2	Electrical Characteristics	10
11	Stability of design guarantee	10

5 List of Tables

Table 1, General Information	1
Table 2, Male Header Compatibility	2
Table 3, Connector Wiring Guide	2
Table 4, Ordering Information	2
Table 5, Changelog	2
Table 6, Absolute Maximum Rating	10
Table 7, Typical Electrical Characteristics	10

6 List of Figures

Figure 1, PE-515	1
Figure 2, Evaluation Kit	4
Figure 3, Ethernet Header Pinout	5
Figure 4, 8 Pin 100BASE-T, Power and LED Connector (Red Wire Indicates Pin 1)	5
Figure 5, External LED Wiring	6
Figure 6, 2D Drawing of PE515	7
Figure 7, PE-515 SMT/THT PCB Footprint	8
Figure 8, Device Markings Outline	9

7 PE-415 Embedded Eval Kit

The PE-415 allows for further testing and debugging within a prototype system before any commitment to custom fixtures or designs is made.

A reference design schematic of the eval kit is freely available to download from the Brainboxes website.

The mating board breaks out all ports and functionality to RJ45 or usable headers for ease when developing a proof of concept.

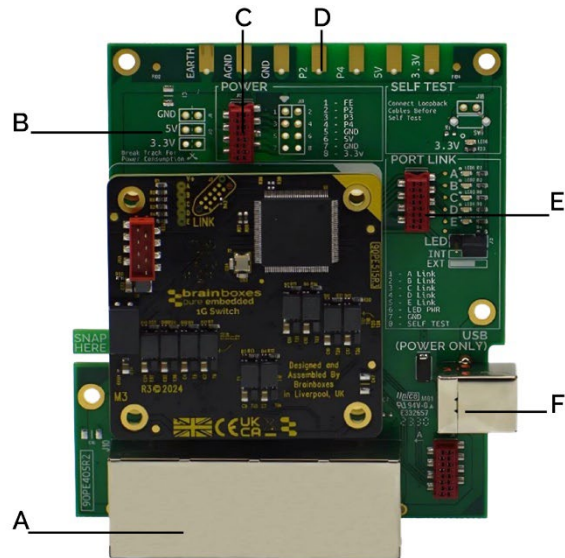

Figure 2, Evaluation Kit

A <- 4xRJ45 and IDC Style Header

B <- Power Consumption Monitoring

- I. The consumption can be monitored on either the 3.3V line, 5V line or the GND return.
- II. To monitor the power consumption, break the track along the dotted line.
- III. Power consumption monitoring is not functional with the USB power supply

C <- Power Header

D <- Power Test Points

E <- Link Header

- I. 2 jumper selectable options:
 - i. Onboard LEDS (INT)
 - ii. External LEDS (EXT)
- II. Ensure to factor in a current limiting resistor for any external LEDS. Improper usage can damage the device

F <- USB Power

8 Design Guide

8.1 Connectors and pinouts

8.1.1 Ethernet Header (8 Pin)

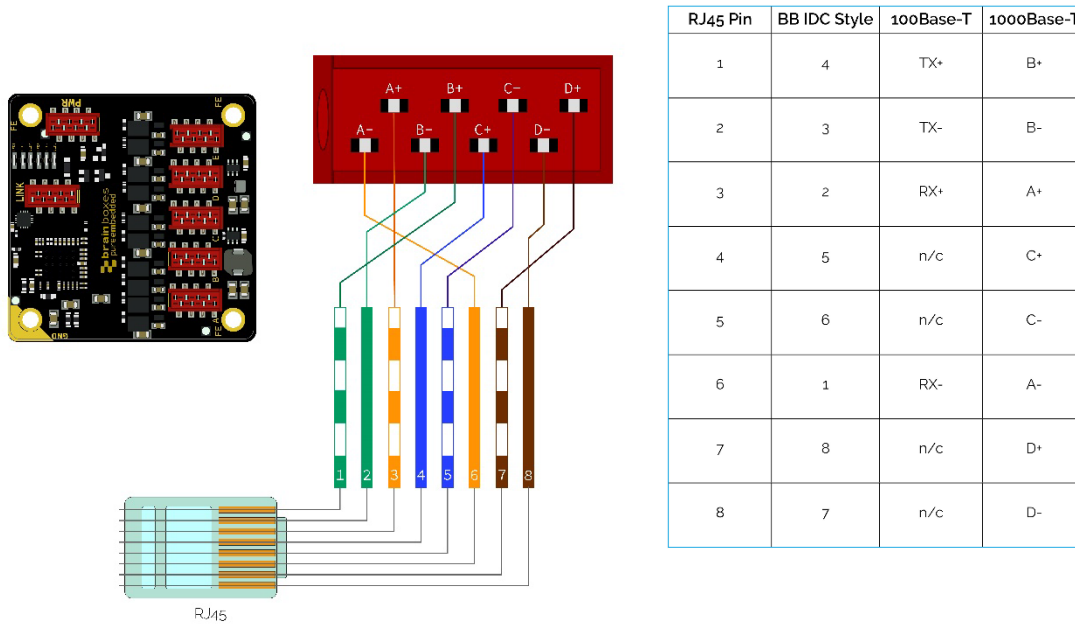

Figure 3, Ethernet Header Pinout

Section 1.3 above details the recommended Pin configuration for the ethernet ports. Coloured CAT5 cable can be wired as shown. For Longer distances (>1.5m) using shielded cable is recommended. Shielding can be attached to the Functional Earth mounting points on the bottom corners of the board

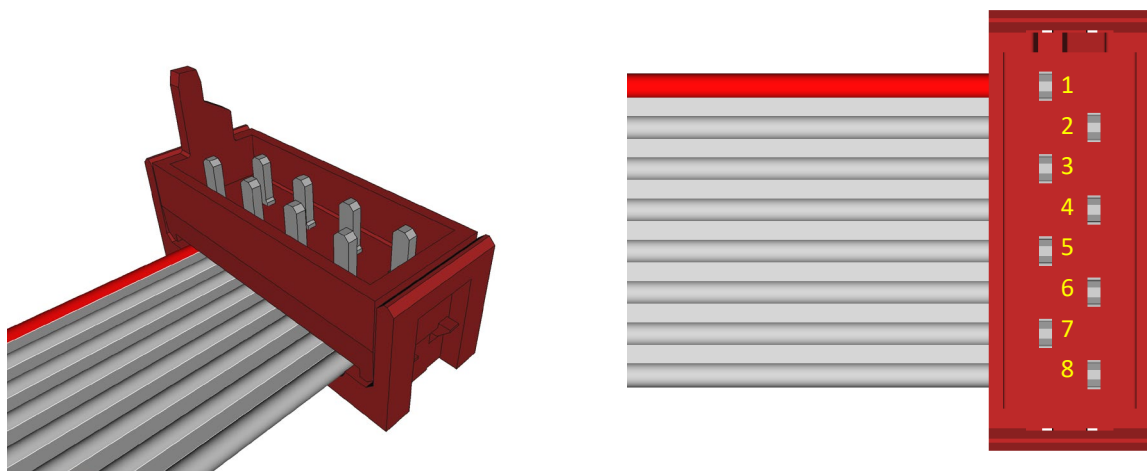

Figure 4, 8 Pin 1000BASE-T, Power and LED Connector (Red Wire Indicates Pin 1)

8.1.2 Link LED Header (8 Pin)

Each port has an Activity Indicator LED and an Activity Indicator Output. The output current must be limited through a resistor. The resistor must be selected to limit the maximum draw to 5mA @ 2.5V. The LEDs must be powered from the LED Power Pin. No other devices should be powered through this header. The LEDs function in an active LOW configuration and should be connected as shown below in Figure 5. The Power draw of any supplementary LEDs is in addition to the specified power on the datasheet. Should it be impractical to implement an electronic-based Link LED forwarding, there are holes of $\varnothing 1\text{mm}$ under each indication LED suitable for housing optical fibres or light pipes of a length less than 50cm.

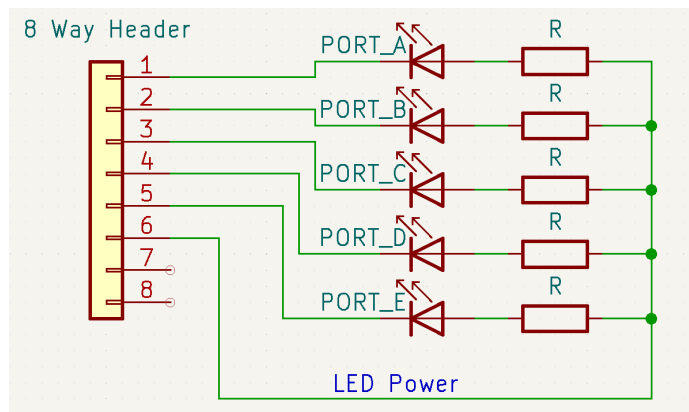

Figure 5, External LED Wiring

8.1.3 Mounting Holes

The 4 x M3 mounting holes are Connected to Functional Earth (FE) or Ground (GND) and labelled accordingly. If the device does not share a common ground with the rest of the system it is recommended to use a nonconductive standoff or isolated mounting point.

8.2 Mechanical Outline

Scale drawings available to download on the Brainboxes website

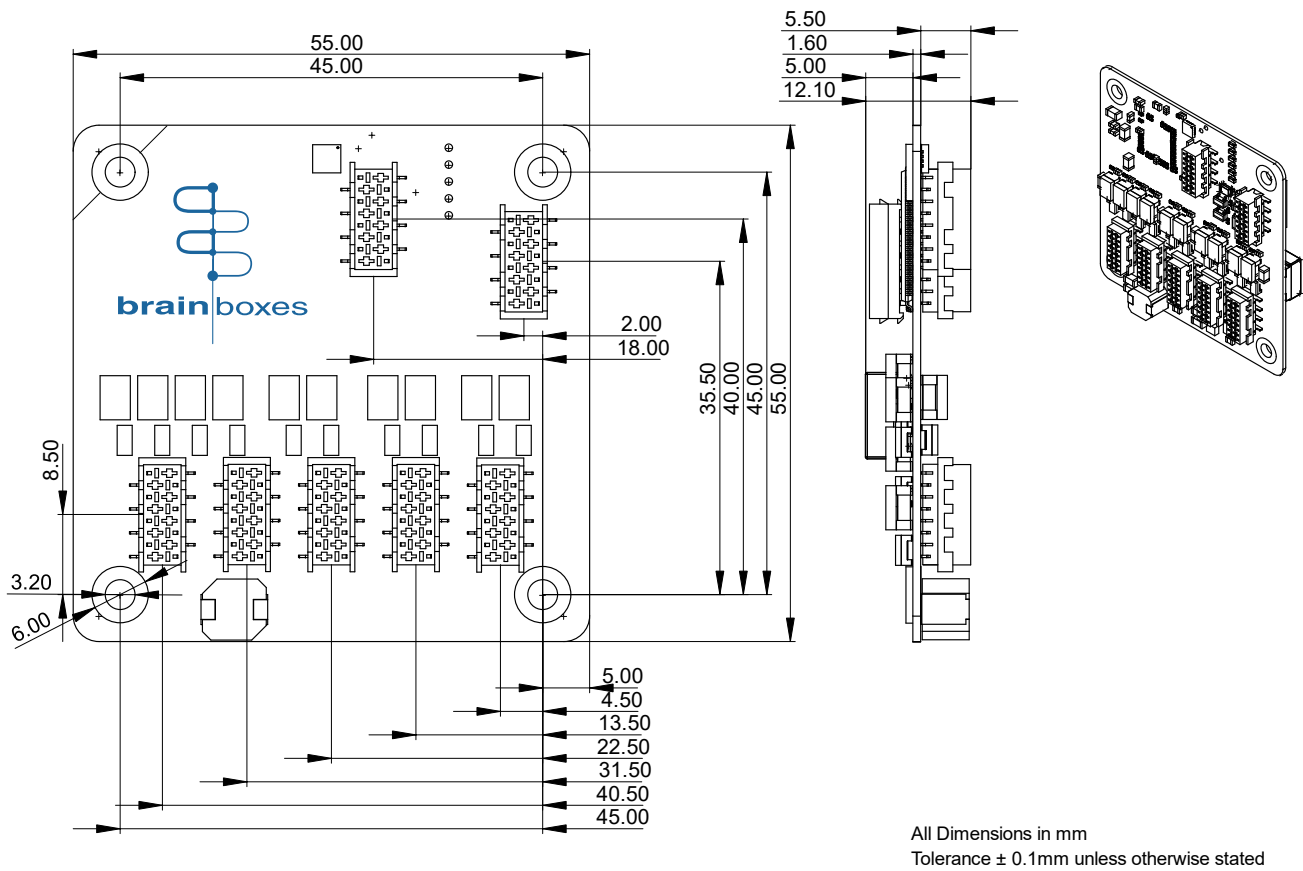

Figure 6, 2D Drawing of PE515

8.3 3D Step File

The full 3D model can be downloaded from the Brainboxes website

8.4 Recommended Footprint

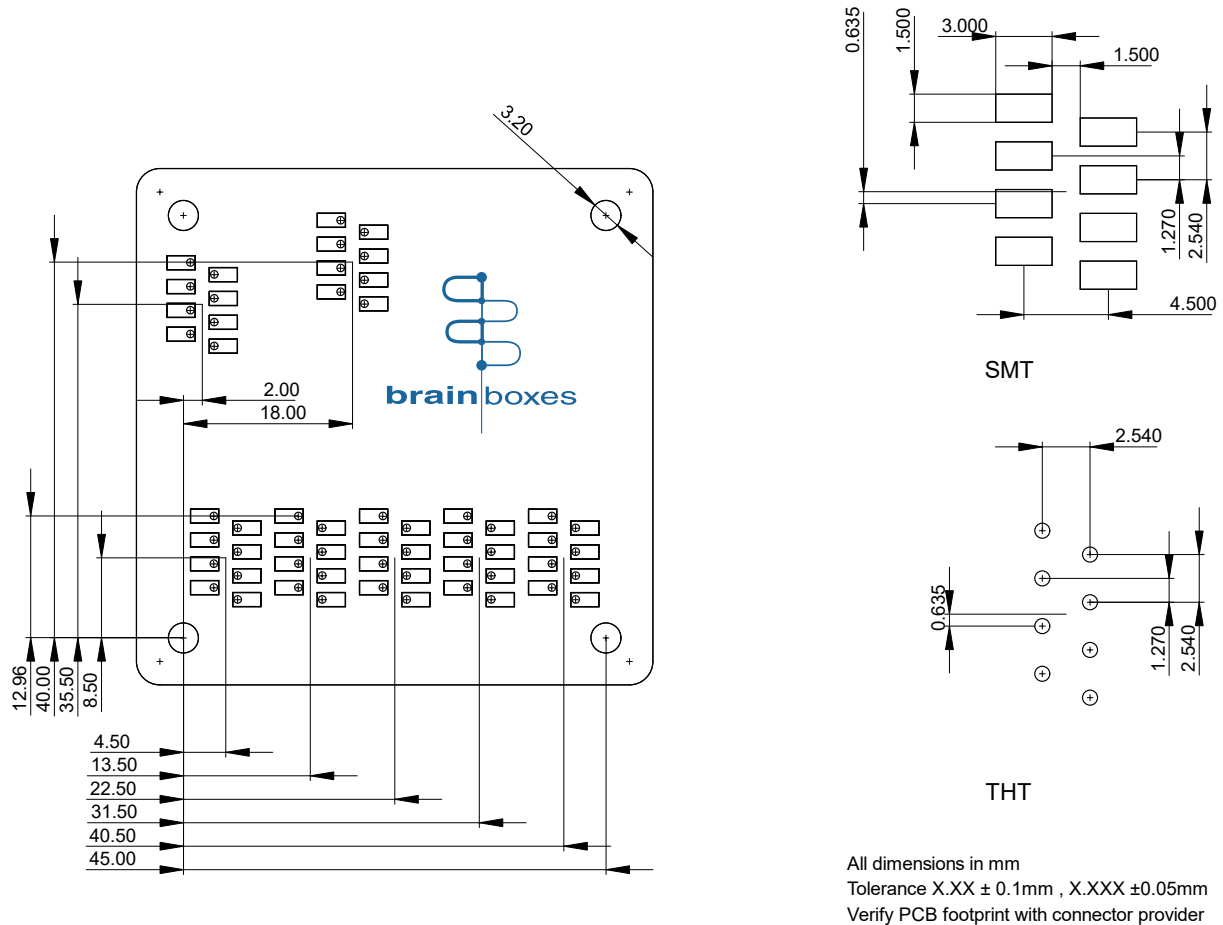

Figure 7, PE-515 SMT/THT PCB Footprint

The mating LED Header and Port Header are not essential and can be excluded if not required. We recommend using through-hole mating connectors for applications where the module is frequently inserted and removed. Avoid placing components within the 55x55 square occupied by the PE-515 where possible. Where not possible, ensure that the Keepout zones given in the 3D Design resources are strictly adhered to. Failure to do so can potentially cause issues with future compatibility. The device should be given 20mm of clearance from the mating surface.

Alternatively, a set of 8-way IDC style headers as detailed in 1.3 above with centre coordinates of (4.5,8.5),(13.5, 8.5),(22.5, 8.5),(31.5, 8.5),(40.5, 8.5), (2,35.5),(18,40)

4 x M3 mounting holes at (0,0), (45,0), (0,45) and (45,45)(GND)

8.5 Routing

When designing custom boards for the PE products, it is important to make considerations for routing the device to connectors or interfaces across a board.

Routing Recommendations:

- Keep Pairs at Uniform distance
- Keep Pairs at as close a length as possible.
- Place a GND plane between different pairs
- Ensure Pairs do not cross plane boundaries
- For more information we recommend reading:
 - Microchip AN2054 (Ethernet Differential Pairs)
 - Texas Instruments SNLA387 (Ethernet PHY PCB Design Layout Checklist)

9 Troubleshooting

9.1 Device Markings

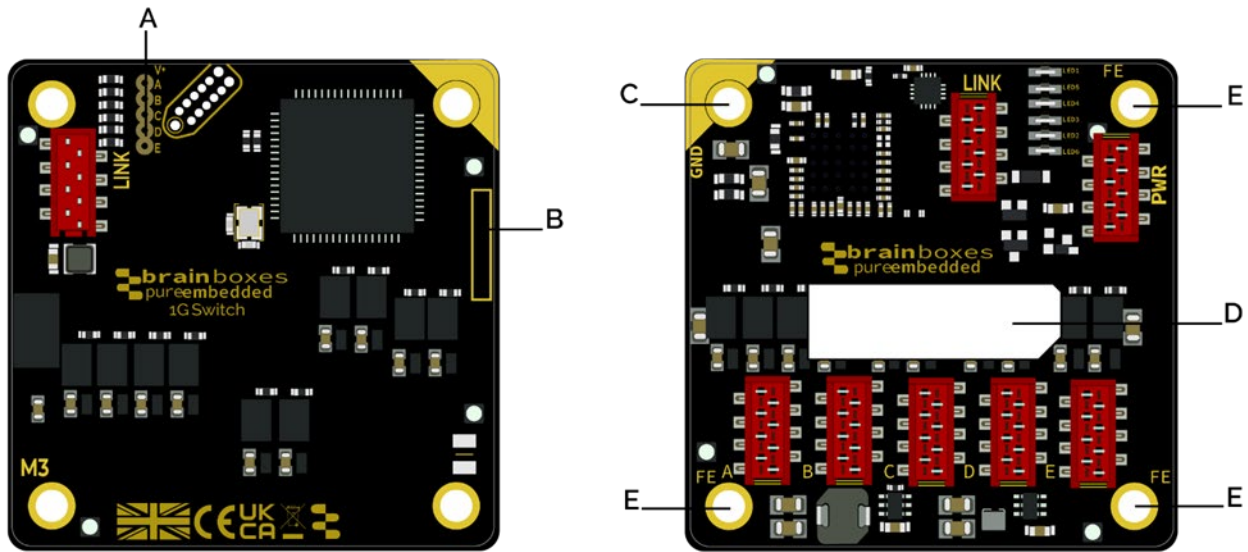

Figure 8, Device Markings Outline

Markings on the rear of this device are subject to change. This will not affect the functionality of the device.

- A <- LED Status Indicators
- B <- 90PE515R3 <- PCB Revision and release year.
- C <- GND Mounting Hole
- D <- Product variant, Serial Number and Date of Manufacture
- E <- FE Mounting Holes

10 Operating Conditions

10.1 Absolute Maximum Ratings

Stresses exceeding absolute maximum ratings may cause permanent damage. Functional performance and device reliability are not guaranteed under these conditions. All voltages are specified with respect to GND.

Table 6, Absolute Maximum Rating

Parameter	Max	Unit	Notes
Supply Voltage	±10V	V	
Ambient Operating Temperature	-40 to 85	°C	

10.2 Electrical Characteristics

Table 7 defines the conditions under which we guarantee proper operation of the Pure Embedded Gigabit Switch.

Table 7, Typical Electrical Characteristics

Parameter	Symbol	Min	Typical	Max	Unit	Notes	
Supply Voltage		3.3		3.45	V		
Supply Voltage		3.27	3.3	5	6	V	
Power Consumption ²	P _{1000MF}		3.2		3.5	W	All port link 1000Mbps Fully active
	P _{100MF}		1.3		1.6		All port link 100Mbps Fully active
	P _{IDLE}		0.5		1		All port no link
LED Output Low	LED On	0		0.4	V		
LED Output High	LED Off	1.9		2.5	V		
Startup time	T _{startup}			100	ms		
Operating Temperature		-40		80	°C		

Sustained operation outside of these conditions will affect long term reliability

11 Stability of design guarantee

Brainboxes has a Product Change Control Policy here: <https://www.brainboxes.com/regulatory-declarations>

² Specified Power Consumption Excludes load attached to the LINK LED header
V1.0 (2025-01-29)