

# HF46F

## SUBMINIATURE INTERMEDIATE POWER RELAY



File No.: E134517



File No.: 40025215



File No.: CQC08001024932



### Features

- 5A switching capability
- 10kV impulse withstand voltage (between coil and contacts)
- Type 2 meets VDE 0700, 0631 reinforce insulation
- Highly efficient magnetic circuit for high sensitivity: 200mW
- Extremely small footprint utilizing PCB area
- Environmental friendly product (RoHS compliant)
- Outline Dimensions: (20.5 x 7.2 x 15.3) mm

### CONTACT DATA

Contact arrangement	1A
Contact resistance	100mΩ (at 1A 24VDC)
Contact material	AgSnO <sub>2</sub> , AgNi
Contact rating (Res. load)	5A 250VAC / 28VDC
Max. switching voltage	277VAC / 30VDC
Max. switching current	5A
Max. switching power	1385VA / 150W
Mechanical endurance	5 x 10 <sup>6</sup> OPS
Electrical endurance	AgNi 2 x 10 <sup>5</sup> OPS (at 3A 250VAC, 30OPS/min) 1 x 10 <sup>5</sup> OPS (at 5A 250VAC, 20OPS/min)
	AgSnO <sub>2</sub> 1 x 10 <sup>5</sup> OPS (at 3A 250VAC, 30OPS/min) 5 x 10 <sup>4</sup> OPS (at 5A 250VAC, 20OPS/min)

### CHARACTERISTICS

Insulation resistance	1000MΩ (at 500VDC)
Dielectric strength	Between coil & contacts 4000VAC 1min
	Between open contacts 1000VAC 1min
Surge voltage (between coil & contacts)	10kV (1.2X50μs)
Operate time (at nomi. volt.)	10ms max.
Release time (at nomi. volt.)	10ms max.
Shock resistance	Functional 98m/s <sup>2</sup>
	Destructive 980m/s <sup>2</sup>
Vibration resistance	10Hz to 55Hz 1.5mm DA
Humidity	98%, +40°C
Ambient temperature	-40°C to 85°C
Termination	PCB
Unit weight	Approx. 3g
Construction	Flux proofed, Wash tight

Notes: 1) The data shown above are initial values.

### COIL

Coil power	200mW
------------	-------

### COIL DATA

at 23°C

Nominal Voltage VDC	Pick-up Voltage VDC	Drop-out Voltage VDC	Max. Allowable Voltage VDC	Coil Resistance Ω
3	2.25	0.18	3.90	45 x (1±10%)
5	3.75	0.25	6.50	125 x (1±10%)
6	4.50	0.30	7.80	180 x (1±10%)
9	6.75	0.45	11.7	405 x (1±10%)
12	9.00	0.60	15.6	720 x (1±10%)
18	13.5	0.90	23.4	1620 x (1±10%)
24	18.0	1.20	31.2	2880 x (1±10%)

### SAFETY APPROVAL RATINGS

UL&CUL	AgNi	5A 125VAC/250VAC at 85°C 5A 277VAC/30VDC at 85°C 3A 125VAC/250VAC at 85°C 3A 277VAC/30VDC at 85°C
	AgSnO <sub>2</sub>	5A 125VAC/250VAC at 85°C 5A 277VAC/30VDC at 85°C 3A 125VAC/250VAC at 85°C 3A 277VAC/30VDC at 85°C B300 R300
VDE	AgNi	5A 250VAC/30VDC at 85°C
	AgSnO <sub>2</sub>	5A 250VAC/30VDC at 85°C

Notes: Only some typical ratings are listed above. If more details are required, please contact us.



HONGFA RELAY

ISO9001, ISO/TS16949, ISO14001, OHSAS18001, IECQ QC 080000 CERTIFIED

2009 Rev. 1.02

## ORDERING INFORMATION

Type	HF46F / 12 -H S 1 T G (XXX)					
Coil voltage	3, 5, 6, 9, 12, 18, 24VDC					
Contact arrangement	H: 1 Form A					
Construction <sup>1)</sup>	S: Wash tight		Nil: Flux proofed			
Termination	1: type 1		2: type 2			
Contact material <sup>2)</sup>	T: AgSnO <sub>2</sub>		Nil: AgNi			
Contact plating	G: Gold plated		Nil: No gold plated			

### Customer special code

- Notes:** 1) Under the ambience with dangerous gas like H<sub>2</sub>S, SO<sub>2</sub> or NO<sub>2</sub>, wash tight type is recommended; please test the relay in real applications. If the ambience allows, flux proofed is preferentially recommended.  
 2) For the application of lamp (except LED), capacitive load, motor load or which can bring high inrush current when relay contacts connect instantly, AgSnO<sub>2</sub> contact material is recommended on priority.

## OUTLINE DIMENSIONS, WIRING DIAGRAM AND PC BOARD LAYOUT

Unit: mm

### Outline Dimensions

HF46F/□□-H□1□□ (□□□)

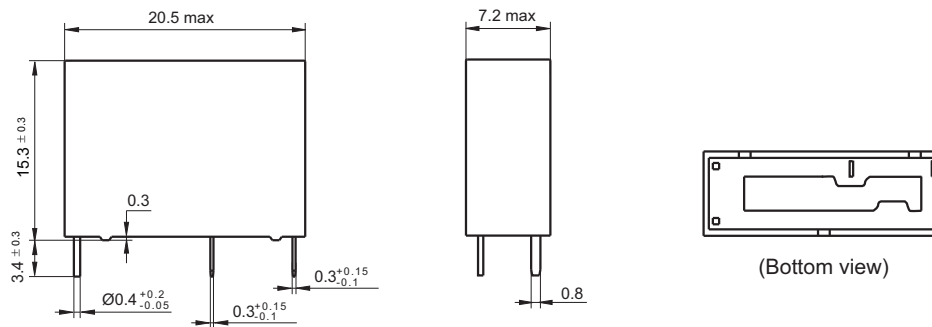

### PCB Layout (Bottom view)

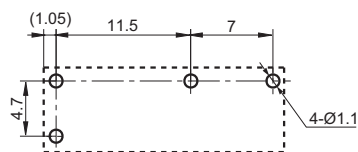

### Wiring Diagram (Bottom view)



# OUTLINE DIMENSIONS, WIRING DIAGRAM AND PC BOARD LAYOUT

Unit: mm

## Outline Dimensions

HF46F/□□-H□2□□ (□□□)

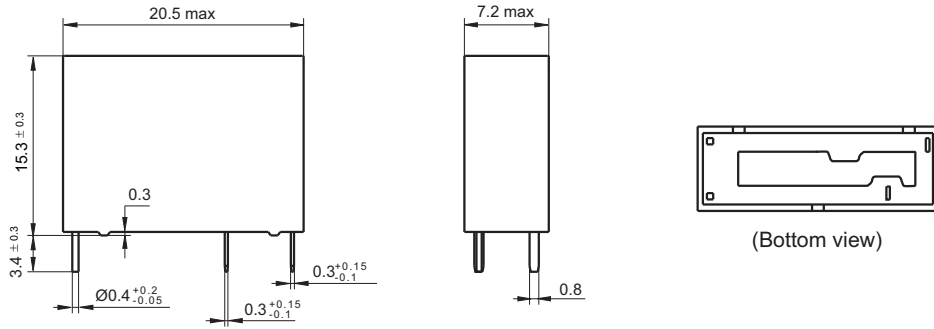

## PCB Layout (Bottom view)

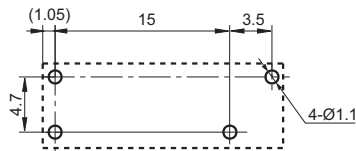

## Wiring Diagram (Bottom view)



- Remark: 1) In case of no tolerance shown in outline dimension: outline dimension  $\leq 1\text{mm}$ , tolerance should be  $\pm 0.2\text{mm}$ ; outline dimension  $> 1\text{mm}$  and  $\leq 5\text{mm}$ , tolerance should be  $\pm 0.3\text{mm}$ ; outline dimension  $> 5\text{mm}$ , tolerance should be  $\pm 0.4\text{mm}$ .  
 2) The tolerance without indicating for PCB layout is always  $\pm 0.1\text{mm}$ .

## CHARACTERISTIC CURVES

### ENDURANCE CURVE

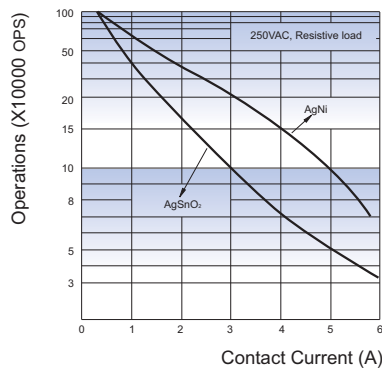

### Disclaimer

This datasheet is for the customers' reference. All the specifications are subject to change without notice. We could not evaluate all the performance and all the parameters for every possible application. Thus the user should be in a right position to choose the suitable product for their own application. If there is any query, please contact Hongfa for the technical service. However, it is the user's responsibility to determine which product should be used only.

© Xiamen Hongfa Electroacoustic Co., Ltd. All rights of Hongfa are reserved.