

Brainboxes US Range Product Manual



Contents

1. Introduction	4
1.1. The US Range	4
1.2. Boost.Software driver	4
1.3. Supported Operating Systems	4
2. Installation Instructions for Windows XP/Vista/7	5
2.1. Windows Vista and XP and Windows7 Installation	6
3. Product Configuration (XP and Vista and Win7).....	9
3.1. Finding your Brainboxes COM port	9
3.2. Port Settings	9
3.3. Changing your COM label	11
3.4. RS422/485 Settings (US-324, US-313, US-346, US-320 and US-842 only)	13
3.5. Advanced Settings – USB Settings	15
4. Uninstallation.....	17
4.1. Uninstalling in Windows XP	17
4.2. Uninstalling in Windows Vista / Windows 7	17
4.3. Brainboxes.Software Uninstaller	19
5. Boost.Software US Card Driver Upgrade / Rollback	20
5.1. Upgrading the Boost.Software Driver	20
6. Troubleshooting and Testing.....	21
6.1. Installation problems.....	21
6.2. Communication Problems	21
7. Lifetime Warranty and Support	22
8. Technical Specifications.....	23
8.1. Supported Serial Settings.....	23
8.2. Device Pin-out	23
8.3. Storage and Operating Environment Guidelines.....	24
9. Regulatory Approvals / Compliance.....	25
9.1. Company Accreditation	25
9.2. Europe – EU Declaration of Conformity	25
9.3. WEEE Directive (Waste Electrical and Electronic Equipment)	25
9.4. RoHS Compliance	26

10. Copyright.....27

1. Introduction

1.1. The US Range

The US range includes 1, 2, 4, and 8 port devices which will provide an RS232 or RS422/485 9-pin COM port to any device with a USB slot.

With large FIFO buffers, the US range offers high data rates of up to 921,600 baud, making high speed serial communications “a breeze” for your system.



1.2. Boost.Software driver

Boost.Software is the device driver for managing the US range from Windows. For a full list of supported Operating Systems, please see the list below:

1.3. Supported Operating Systems

The US Range can be used in the following Microsoft Operating Systems with the supplied drivers;

- Windows Vista 32-bit
- Windows Vista 64-bit
- Windows XP 32-bit
- Windows XP 64-bit
- Windows 7 32-bit
- Windows 7 64-bit

Brainboxes Boost.Software drivers have undergone Microsoft testing with the US-Range. Upon passing these tests, the drivers were signed by Microsoft, as an indication of their quality and stability.

2. Installation Instructions for Windows XP/Vista/7

PLEASE READ CAREFULLY

- The Setup.exe program will install all the driver files required to guarantee a smooth and straightforward installation
- Please ensure all Brainboxes devices are disconnected before starting the installation program.
- If any previous Brainboxes Boost.Software drivers are found, you will be notified on what action to take.
- Follow the instructions below to start the installation process.

If you have any issues with installation, please follow the steps in Section 4: Uninstallation, then attempt to install again. If you still have issues, see Section 6: Troubleshooting and Testing

2.1. Windows Vista and XP and Windows7 Installation

1. With the laptop turned on, insert the CD
2. If the CD does not autorun, Go to Start → My Computer → Right Click the CD and select Explore. This will open the CD in Windows Explorer for browsing the contents of the CD.
3. Locate the “Setup.exe” program on the CD and double click to launch.
4. Ensure all US Card devices are REMOVED before proceeding. Otherwise installation may not complete successfully.
5. Click Next



6. The drivers will then be installed. This may take a while, depending on your system.

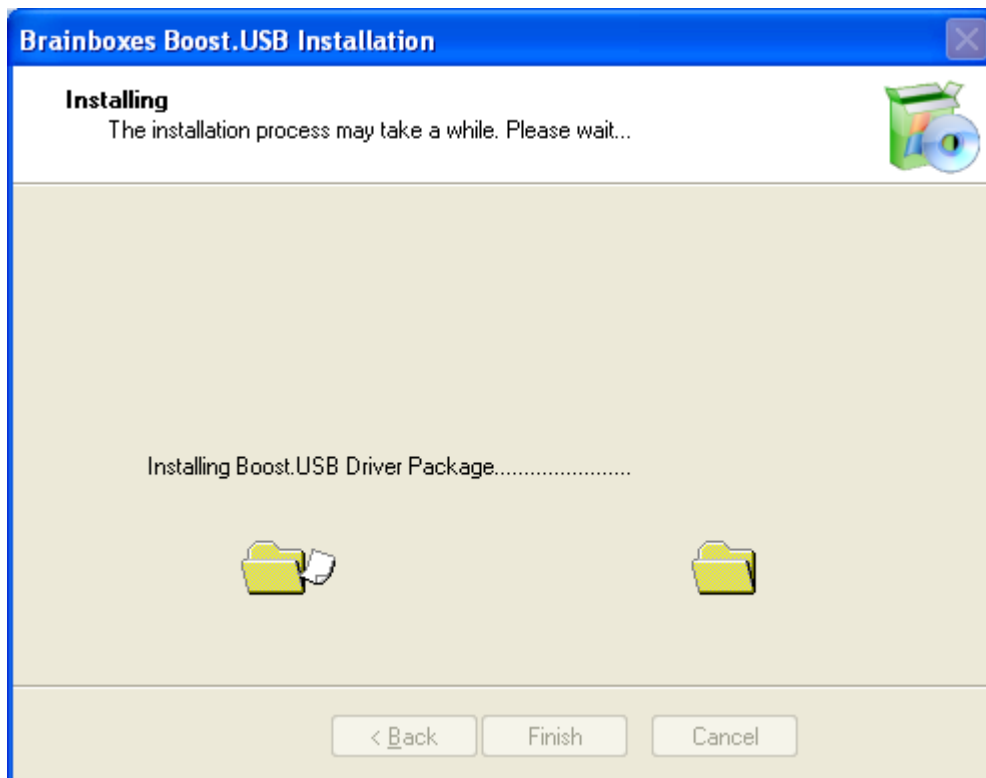

7. Installation Complete. Click Finish.

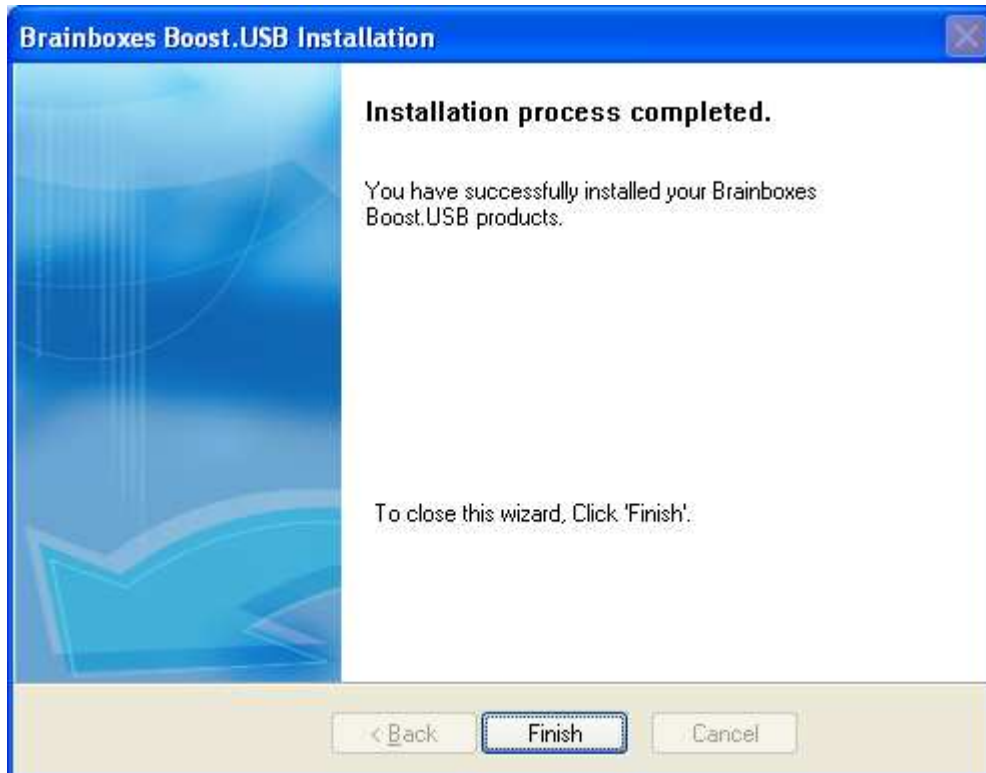

8. Insert your US Product (s).

9. Pop up balloons will appear as the device is recognised by the preinstalled drivers. The example below is for a US-101, and may differ slightly per product.



10. Once installation is complete (indicated by last balloon above), your device will now be ready to use.

11. You can check the COM Number of the Port, by opening Device Manager (See **Section 3.1: Finding your Brainboxes COM port**). If you need to change the COM port number, see **Section 3.3 Changing Your COM Label**.

3. Product Configuration (XP and Vista and Win7)

Note: Images below show an RS232 US Card as an example. The same settings are available for RS422/485 US Cards

3.1. Finding your Brainboxes COM port.

- **Open** Device Manager (Found by Right Clicking on My Computer and clicking *Manage*. Then Select *Device Manager* from the left hand pane.)
- **Find** the Brainboxes Serial Port entry in Device manager. (Found under the 'Ports' section)
- The Brainboxes Serial Port entry displays the current COM number in brackets after the name. (This is usually *COM3* following install, but may be different if other serial devices have been installed in the past)
- To change your COM label, see **Section 3.3: Changing your COM label**

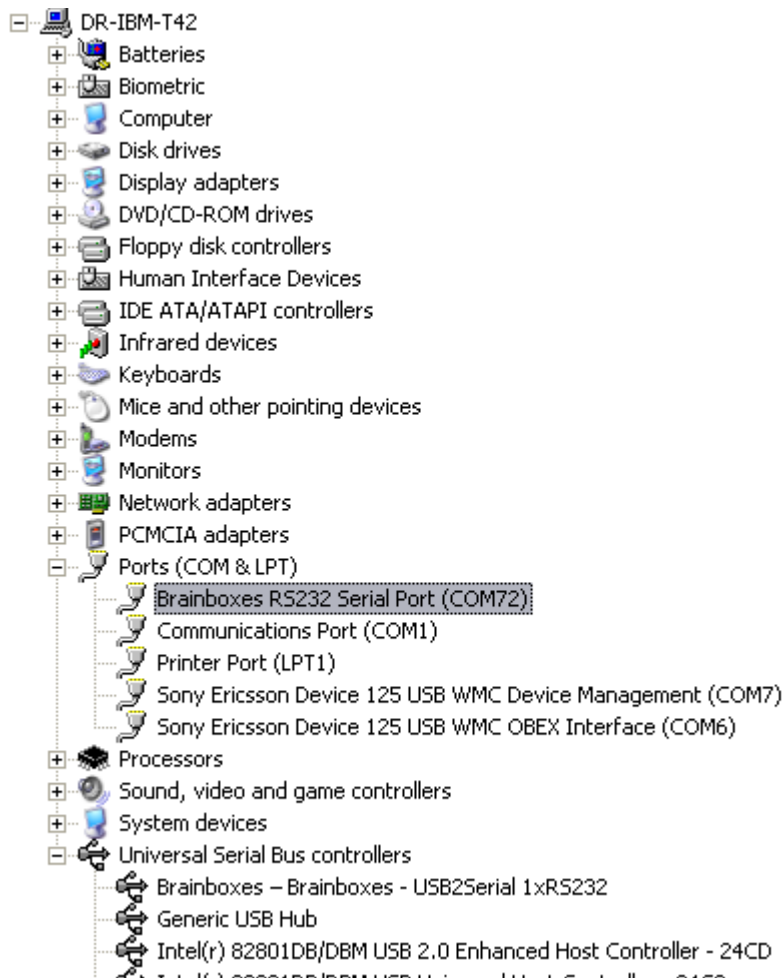

3.2. Port Settings

The Port Settings allow you to set Default or Override Settings for the serial communication and how to deal with incoming hardware handshaking events.

- To open '*Port Settings*', open device manager and **Double Click** on the Brainboxes COM Port Entry under the '*Ports*' section

- Then Click on the 'Port Settings' tab.

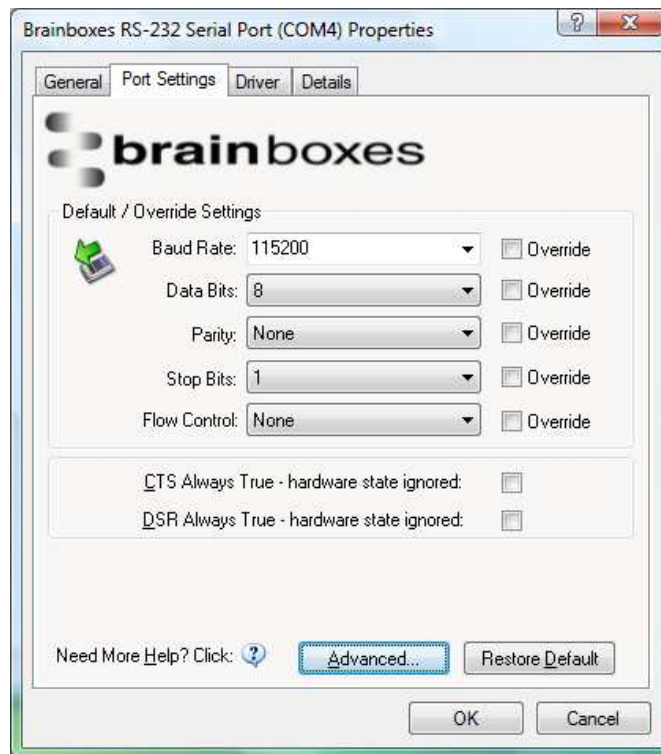

- All options can be selected from the Dropdown Menus. In addition, you can enter a non-standard value into the Baud rate

NB – Once the desired settings have been achieved, you must click **OK** to activate them. At anytime click the 'Restore Default' button to return to the original setup.

Default / Override Settings

- The “**Default Settings**” will be set if an application does not specify the serial settings when it opens the COM Port.
 - This is sometimes the case with old Legacy applications and you will need to choose these settings to match the communications that you wish to use.
 - The majority of Applications will specify what Serial Settings they wish to use. In this case, it will not matter what the Default settings are, as the Port will be opened with the Application’s Settings.
- When the ‘**Override**’ box is checked next to the Default Setting, the Port will communicate at this setting whether an application has requested it or not.
 - For example, this will enable you to force baud rates that your application does not allow you to select. This can be useful for interfacing to equipment which uses higher baud rates or unusual baud rates, which your application does not support.
 - In a case where you want to use hardware handshaking, but your application is not capable, you can select RTS / CTS Always True – Hardware state ignored and choose to Override it.
 - **NB** with the use of Override Settings, you need to ensure that the equipment you are connecting to is setup to match the communications settings you are forcing.

CTS / DSR Always True

- CTS and DSR are incoming hardware handshaking lines. This means they receive signals from the connected device which tell the US Card when it is and isn’t OK to send data.

- Sometimes these signals may want to be ignored. By forcing CTS or DSR True, the US Card will ignore those signals and always send data.
- These settings are especially helpful when CTS and DSR are not physically connected (such as in a 3 wire setup) and it is not acceptable for the data flow to stop and start due to arbitrary variances on the unconnected signal lines.

3.3. Changing your COM label

- If you need to change the COM label, **Double click** on the Port entry in Device Manager
- Click on the '*Port Settings*' tab and click **Advanced**

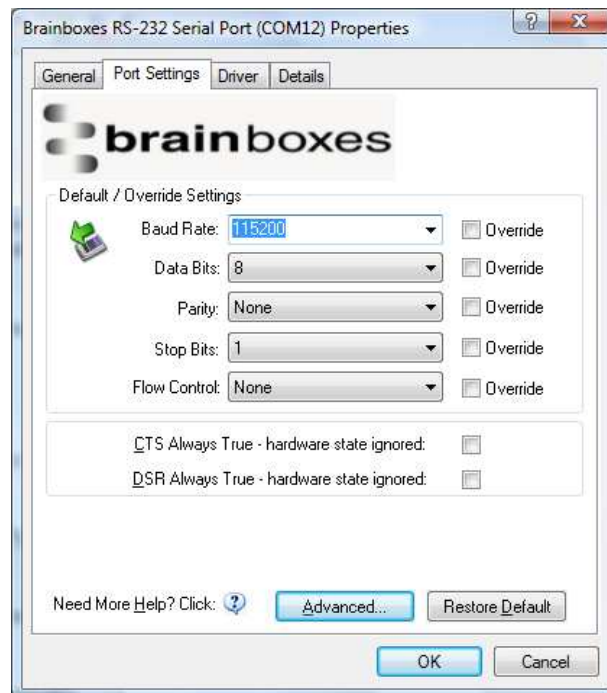

- A new COM Port label can be selected from the dropdown menu. Click **OK** to set the new COM Label.



- If the COM Port number is labelled “*in use*”, it is either currently used by a COM Port present on the system, or is reserved for a device which is not currently present. It is possible to select this COM number and force the change, if you are sure it is not required by any other device.

3.4. RS422/485 Settings (US-324, US-313, US-346, US-320 and US-842 only)

For RS422/485 products only, there is an additional tab in the Advanced Settings to allow you to change duplex mode.

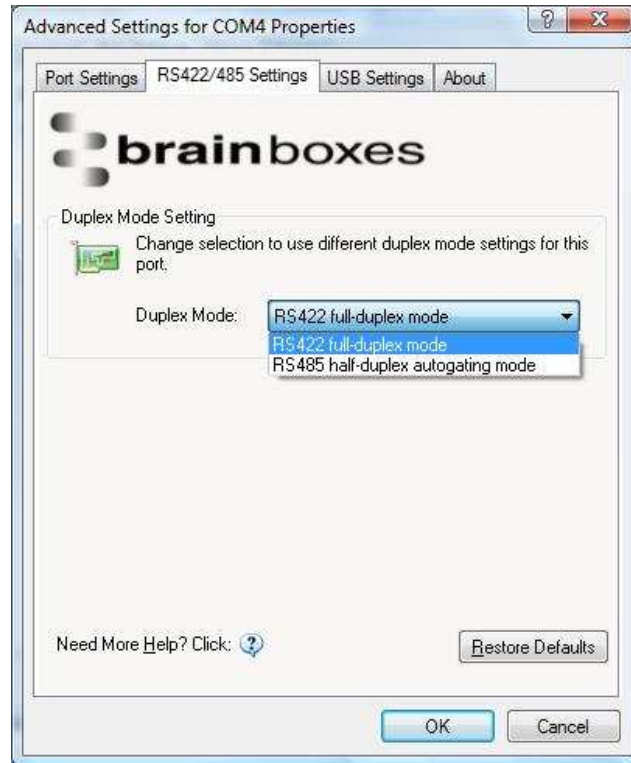

- The drop down list allows users to choose the desired RS422/485 operations mode.
- Select “RS422 full duplex mode” for Full Duplex communications.
- Select “RS485 half duplex autogating mode” for Half Duplex communications.
- For further details on wiring, see **Section 8.2: Device Pinout**
- Restore Defaults: Pressing this button will reset all settings on this Property Page back to the factory defaults of this device. The default settings for this Property Page are “RS422 full duplex mode”.

Background Information:

- DTR/DSR Handshaking is not available on 422/485 devices.
- Full Duplex Mode

This mode is generally used between one transmitter / receiver to only one other transmitter / receiver, but it is possible for each output to drive up to 10 receivers.

Generally, in RS422 systems, all 8 signal lines from the 9 pin D connector participate in the data transfer sequence. Thus 4 twisted pair cables are used. One twisted pair carries the TXD data outwards, one pair brings the RXD data inward, another pair carries the RTS handshaking signal outwards, and the fourth pair brings the CTS handshaking signal inwards. There is no need to carry the ground from one device to another.

- Half Duplex Autogating Mode

The RS485 standard is similar to the RS422 standard upon which it is based. The main difference is that up to 32 transmitter / receiver pairs may be present on the line at one time.

Although the card uses a 9 pin D connector, generally not all the lines are used for RS485 systems. The RTS+/- and CTS+/- lines, though driven by the card, are usually not connected. In two wire Half-Duplex configuration, the TXD+ line is connected to RXD+, whilst the TXD- line is connected to RXD-. Only one pair of twisted wire cable is used in RS485 Half Duplex communication.

These are the two main wiring schemes:

- RS485 One Talker Many Listeners (Half Duplex)
- RS485 Many Talkers Many Listeners (Half Duplex)
- Please see Section 8.2: Device Pinout for wiring diagrams.

3.5. Advanced Settings – USB Settings

The Advanced USB Settings for the Brainboxes COM Port allow you to get the best performance from your device and system. There are two choices, dependant on whether minimal CPU usage or Data Latency (delay) is the main concern.

The default settings have been carefully selected and should provide great performance for the majority of users. The USB Settings will help if you need to lower the CPU usage, or your application is timing critical and requires a lower Data Latency

- To open Advanced Settings, open the Port Settings (as described in section 3.2) and click the **Advanced** button.
- **Select** the '*USB Settings*' tab.

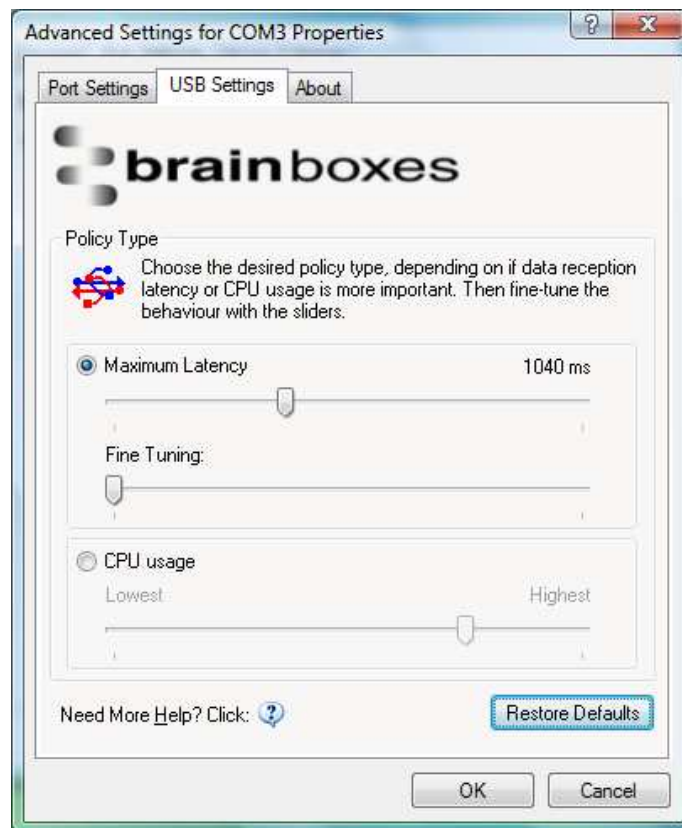

NB – Once the desired settings have been achieved, you must click **OK** to activate them. At anytime click the '*Restore Default*' button to return to the original setup.

Maximum Latency

- Maximum Latency will allow you to choose the maximum time taken for received data at the 9 Pin connector of the port to be processed and passed to the Application.
- The slider is non-linear, which allows settings for small latencies to be adjusted more accurately than those for larger latency values, where accuracy is less important.
- **NB** – The maximum latency value can not be guaranteed on all systems. Only drivers on Real-Time Operating Systems can guarantee latency times. Due to technical limitations, for baud rates below 1200 baud and maximum latency settings below 45ms, the actual latency will be higher than expected

- The Fine tuning slider may be useful to obtain the best performance whether your application is sending small bursts of information, or is continuously streaming the data.
- This slider will allow tuning the behaviour to suit the needs of the specific application. While maintaining the Maximum Latency value chosen above, smoothness of data reception, and CPU usage can be improved by choosing the best fine tuning option.
- Data reception behaviour is very different when comparing reception of continuous streaming data without gaps to the reception of 'occasional' data - data with gaps in the data stream.
- **NB** – There is no quantitative value attached to this slider. To find the optimum value, trial and error is required.

CPU Usage

- Selecting the CPU Usage radio button and moving the slider to the left-most position will give the lowest CPU Usage behaviour, saving your CPU clock cycles for other processing. Nevertheless, the impact on latency and smooth data flow might be too severe.
- To lessen the impact, change this slider until optimum system behaviour is achieved. CPU Usage will increase the further the slider is moved to the right.
- **NB** – There is no quantitative value attached to this slider. To find the optimum value, trial and error is required.

4. Uninstallation

You can uninstall the Brainboxes Boost.Software drivers at any time, with or without the Card inserted into the Laptop. The un-installation steps below is applicable to all cards in the US range.

4.1. Uninstalling in Windows XP

- **Open** Control Panel, and then open “*Add or Remove Programs*”
- **Click** on the “*Brainboxes Boost.Software Device Driver Suite*” and then click **Change/Remove**
- The Brainboxes Boost.Software installer will launch. Please see **Section 4.3: Brainboxes Boost.Software Uninstaller**

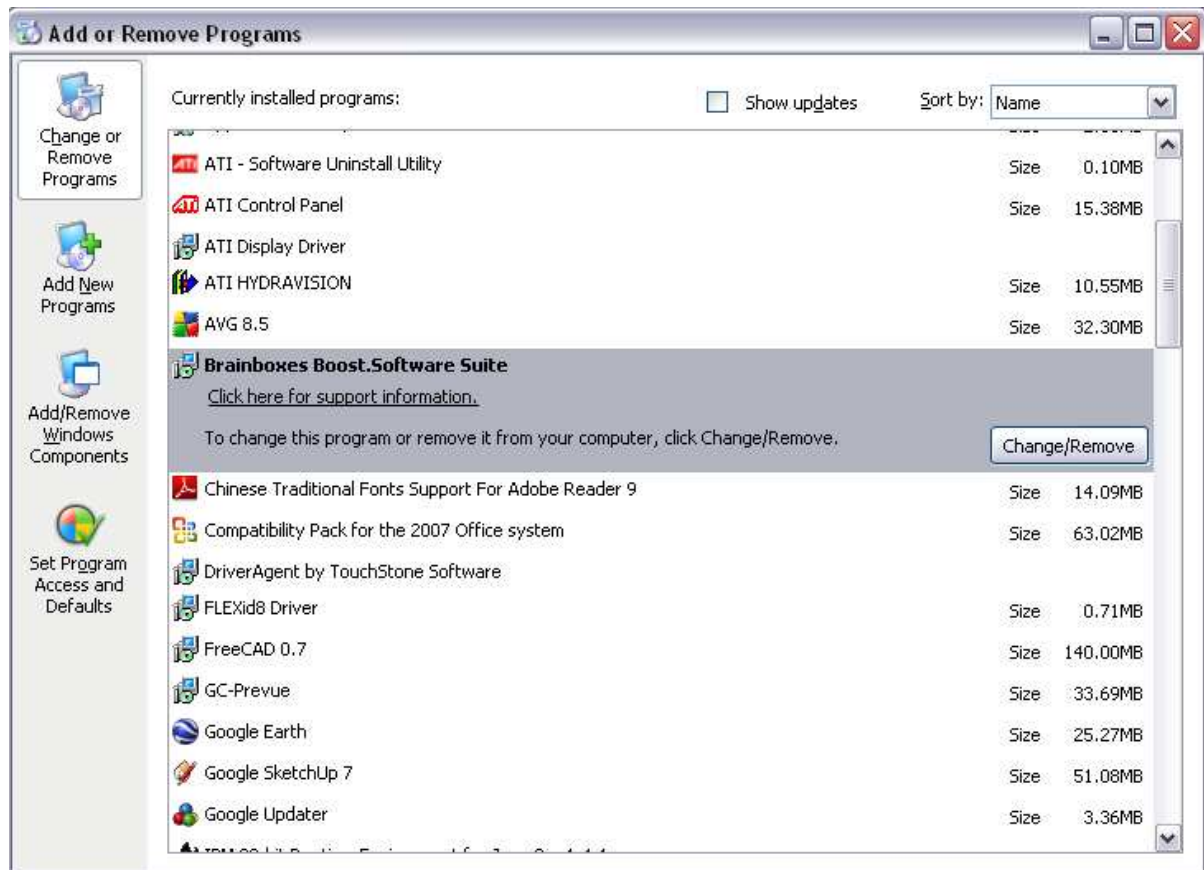

4.2. Uninstalling in Windows Vista / Windows 7

- **Open** Control Panel, and then open “*Programs and Features*”
- **Click** on the “*Brainboxes Boost Software.Suite*” and then click **Uninstall/Change**
- The Brainboxes Boost.USB installer will launch. Please see **Section 4.3: Brainboxes Boost.Software Uninstaller**

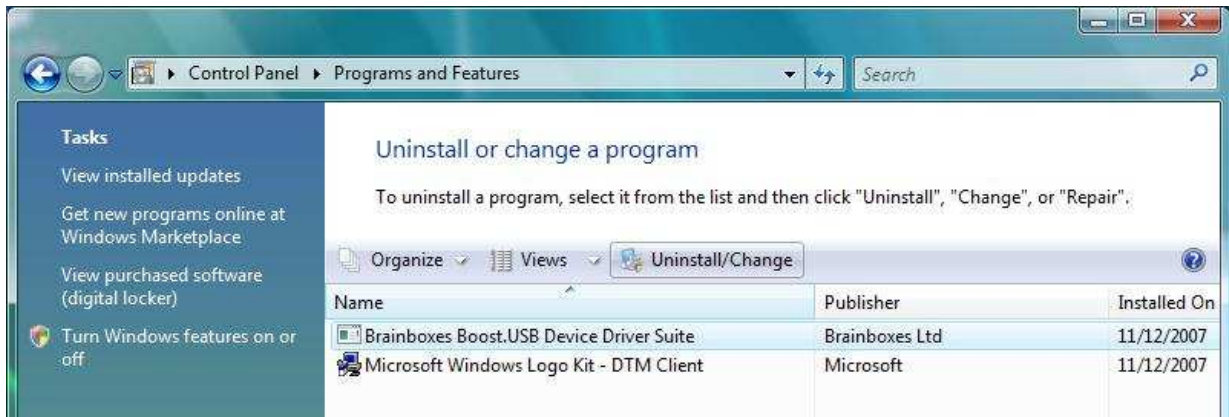

4.3. Brainboxes Software Uninstaller

- The Brainboxes Uninstallation wizard will launch, which will remove all driver files and associated registry entries. Just click **Next** on each page of the Wizard. When the drivers have been uninstalled, click **Finish**.

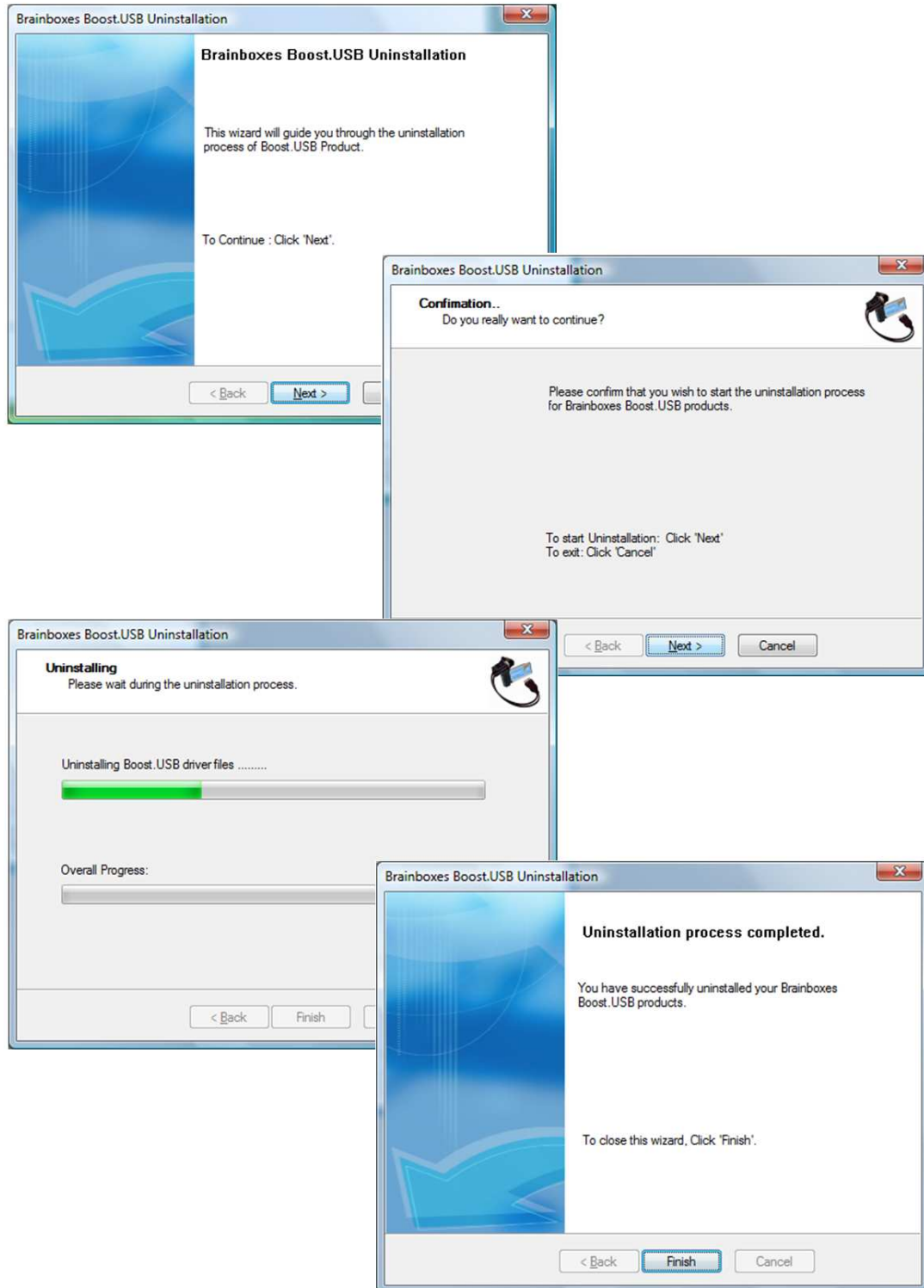

- When finished, you may unplug your US Card. To reinstall, simply plug in the card again and follow the installation instructions as in Section 2: Installation Instructions.

5. Boost.Software US Card Driver Upgrade / Rollback

There are two parts to the Boost.Software, US Range driver:

(Taking for example the US-101 1 Port RS232 Device)

- Card driver: “Brainboxes – Brainboxes - USB2Serial 1xRS232”
- Port driver: “Brainboxes RS232 Serial Port (COM3)”.

NB If you need to upgrade or roll back the Boost.Software driver, we recommend to completely uninstall the existing drivers first, and then to install the new drivers from fresh. This will restore all settings to factory default. However, if you instead wish to retain your settings, you can use the ‘Update Driver’ or ‘RollBack’ in Device Manager for upgrading/rolling back the US Card driver.

5.1. Upgrading the Boost.Software Driver

1. Go to Device Manager and Right Click on the USB2Serial entry (Found under Universal Serial Bus Controllers – see image below)

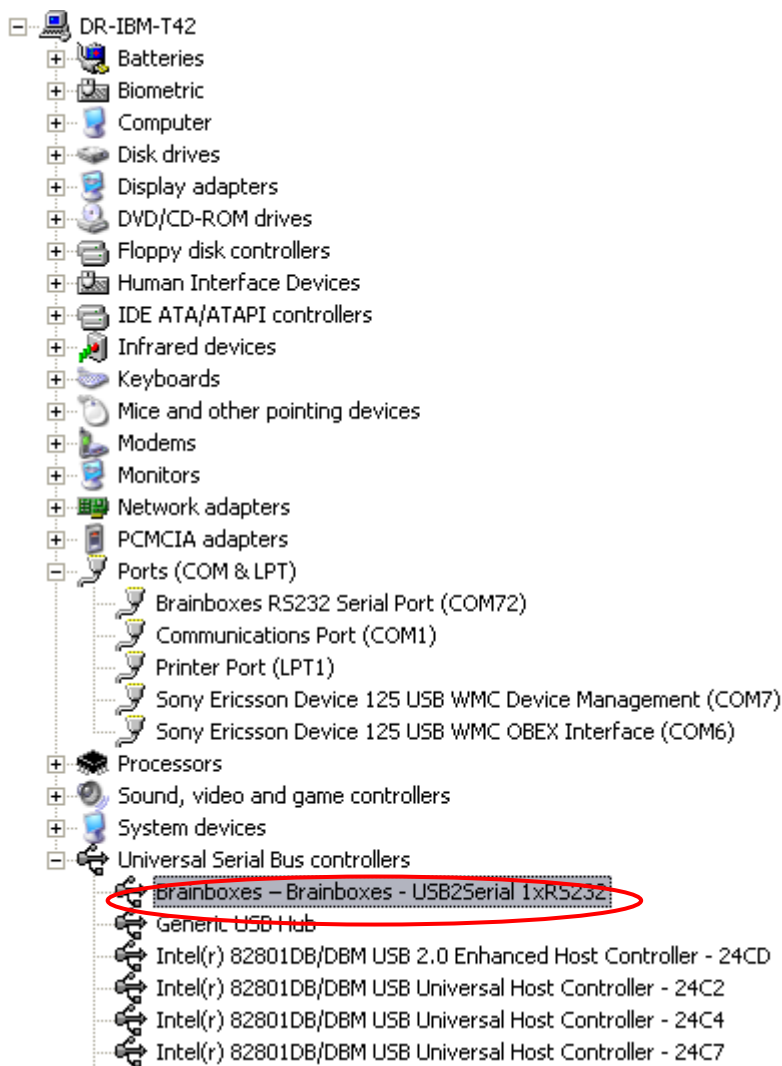

2. Select Upgrade Driver. This will launch the Found New Hardware Wizard. Follow the on screen instructions.

NB: It is only possible to upgrade the Boost.Software driver via the Serial Card entry in Device Manager and not the Serial Port entry. The upgrade process will automatically upgrade the Port driver.

6. Troubleshooting and Testing

6.1. Installation problems

- Check the US Card is correctly installed, and the Ports appear in Device Manager without any errors (Errors are indicted by a yellow exclamation mark)
- If the installation did not complete or shows any error messages then restarting the computer sometimes helps.
- If Device Manager is still showing error messages, it is wise to uninstall and re-install. This should cure issues such as Resource Conflicts or failed installations. See **Section 4: Uninstallation and Section 2: Installation Instructions**.
- If the problem is still present after trying the above, try another laptop to narrow down the problem.
- Should the problem still persist, please contact [Brainboxes Technical Support](#)

6.2. Communication Problems

If you are experiencing communication problems:

- Try removing the card and reinserting as this can sometimes help.
- Check the US card is correctly installed, and the Ports appear in Device Manager without any errors (Errors are indicted by a yellow exclamation mark). If there are any errors follow **Section 6.1**.
- Perform a loopback: A loopback test will confirm that your card is able to Transmit and Receive Data. The Transmit and Receive lines will need to be connected so that any data sent out of the card is then received back on the same Port. Please use the Brainboxes Loopback Test Application to perform a loopback test. [Click here to Launch Loopback test](#)
- If a loopback test passes, please contact [Brainboxes Technical Support](#)

7. Lifetime Warranty and Support

To receive the lifetime Warranty, you need to register your product with us using our online form.

NB: this must be done within 28 days of Purchase.



[Lifetime Warranty Sign up](#)

* Terms and Conditions are available online. Standard warranty period is 3 years if a product is not registered.



Since 1983, Brainboxes have designed, tested and manufactured our products all under one Roof. One of our greatest strengths is in after sales service. Technical Support is provided by members of our Test Team, who know our products inside out and have direct access to the chip and board designers as well as the technicians who built and tested your product.

If you have any issues, questions or suggestions about our Products and Services, then please contact us.

Technical Support is free*. As long as you have a Brainboxes Product we will be happy to help, even if it's discontinued or out of warranty. Excellent Customer Service, just as it should be.

For the quickest solution to your issue, if you email us, please include as much detail of your setup and the fault you are experiencing.

* Standard rate call charges for phone support apply.

Email

Technical Support: support@brainboxes.com

Sales Enquiries: sales@brainboxes.com

Telephone

You can speak to Brainboxes Support or Sales teams direct,

Monday – Friday, 9am to 5pm (UK time)

Tel: +44 (0)151 220 2500

8. Technical Specifications

8.1. Supported Serial Settings

Serial Setting	
Baud Rate	300 to 921,600
Data Bits	7 or 8
Parity	None, Odd, Even, Mark & Space
Stop Bits	1 or 2
Handshaking	RTS/CTS DTR/DSR Xon/Xoff
Break	Supported

8.2. Device Pin-out

8.2.1. RS232 Devices (US-101, US-257, US-235, US-701, US-279)

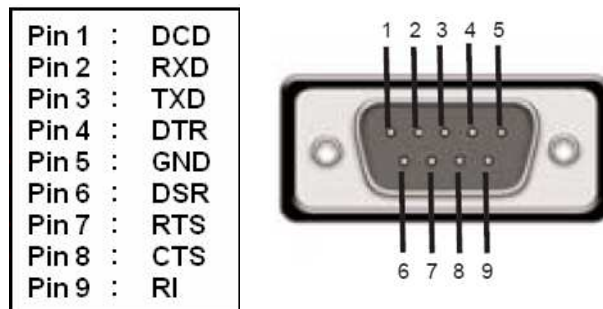

8.2.2. RS422/485 Devices (US-324, US-320, US-313, US-346, US-842)

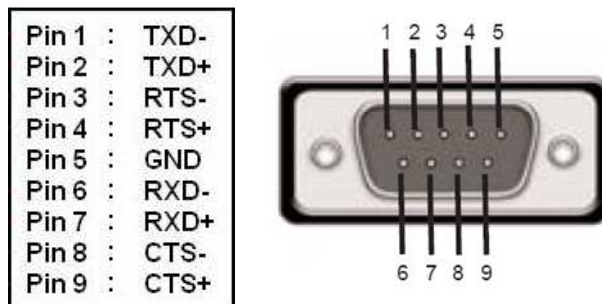

PLEASE NOTE:

- DTR/DSR Handshaking is not available on RS422/485 devices
- For **RS422 FULL Duplex** Communications, please note the pin outs above.
- To achieve **RS485 Half Duplex** Communications, using two wires for communication, Pins 1 and 6, 2 and 7 must be physically shorted.
- Once your wiring is setup, you will also need to set the card to FULL or HALF Duplex mode in the software. For further details, see **Section 3.4: RS422/485 Settings**

8.3. Storage and Operating Environment Guidelines

Storage

Temperature: -10°C to $+70^{\circ}\text{C}$

Humidity: 8% to 95% non-condensing

Operational

Temperature : 0°C to $+70^{\circ}\text{C}$

Humidity : 20% to 75% non-condensing

9. Regulatory Approvals / Compliance

For up to date details of global certifications, please check the product datasheet on the Brainboxes website.

9.1. Company Accreditation

Brainboxes achieved accreditation to the ISO14001 environmental standard early 2008. This globally recognised standard ensures Brainboxes can demonstrate effective management of all its environmental impacts, together with a process of continuous improvement.

Brainboxes have also been an ISO9001 registered company since 1994. This has ensured that Brainboxes products, right from design to manufacture, have been produced to the highest standards. We operate this Quality Management System through out the company, and it is subject to regular external surveillance visits.

Brainboxes have always been aware of the need to continually review company processes and has been working with National Quality Assurance (www.nqa.com) since 1994, helping the company to create and maintain internationally recognised accreditation standards.

Linked with our Lean and Six Sigma techniques, we believe we have the most reliable products on the market, and to back this up we are offering a Lifetime Warranty* on all our Serial Products.

9.2. Europe – EU Declaration of Conformity

The US devices conform to the protection requirements of European Council Directive **2004/108/EC**

The products are designed to meet the standards detailed below. The Declaration of Conformity and supporting Technical Construction File is available by request from Brainboxes.

<p>EN 55022:1998 A2:2003 Class A</p>	<p>Information technology equipment — Radio disturbance characteristics — Limits and methods of measurement</p>
<p>EN 55024:1998 A2:2003 Class A</p>	<p>Information technology equipment — Immunity characteristics — Limits and methods of measurement</p>

9.3. WEEE Directive (Waste Electrical and Electronic Equipment)

The WEEE Directive 2004/96/EC came into force, in the UK, at the beginning of 2007.

Customer Responsibilities

You are encouraged to dispose of WEEE in an environmentally friendly way.

This can be done through your local civic amenities site, an approved treatment facility or alternatively through a relevant compliance scheme.

Brainboxes' Responsibilities

Brainboxes has a legal responsibility, as producer, to provide a free of charge collection service to our customers for our obligated WEEE.

Brainboxes is defined as a producer under the WEEE Regulations because we sell own

brand Electrical & Electronic Equipment (EEE) in the UK. Our WEEE **Producer Registration Number** is **WEE/AH0004XR**. For more information, [click here](#).

For details of our WEEE recovery service options, please see our Website, or email us at: weeerecovery@brainboxes.com

9.4. RoHS Compliance

All Brainboxes Serial and Bluetooth products are fully RoHS compliant.

Brainboxes identified at an early stage the importance of rapid compliance to RoHS guidelines and established a project team to actively manage the transition. The initial step in the process was to use our close relationships with suppliers to ensure early access to RoHS compliant components for all of our Bluetooth and Serial Products. In addition, the project team worked to ensure that our manufacturing processes meet all RoHS requirements well in advance of the deadline.



To verify supplier declarations on RoHS compliancy, we have also sent fully built products to an external test house for X-Ray Fluoresence testing on components, using the Fischerscope X Ray system XDAL. This technique is capable of determining percentages of different elements and is accurate to 0.1% Wt.

RoHS Compliant Brainboxes products have been available since January 2005.

What is the RoHS Directive?

The RoHS directive (2002/95/EC the Restriction of the use of certain Hazardous Substances in Electrical and Electronic Equipment) prohibits the sale of electrical and electronic equipment containing hazardous substances. A list of these hazardous substances includes lead, cadmium, mercury, hexavalent chromium, polybrominated biphenyls and polybrominated diphenylethers. RoHS affects each and every electronics manufacturer, directly or indirectly, regardless of geographical location or the equipment they produce.

10. Copyright

Copyright © Brainboxes Ltd

All rights reserved. No part of this hardware, circuitry or manual may be duplicated, copied, transmitted or reproduced in any way without the prior consent of the Manufacturer