

Hardware Manual

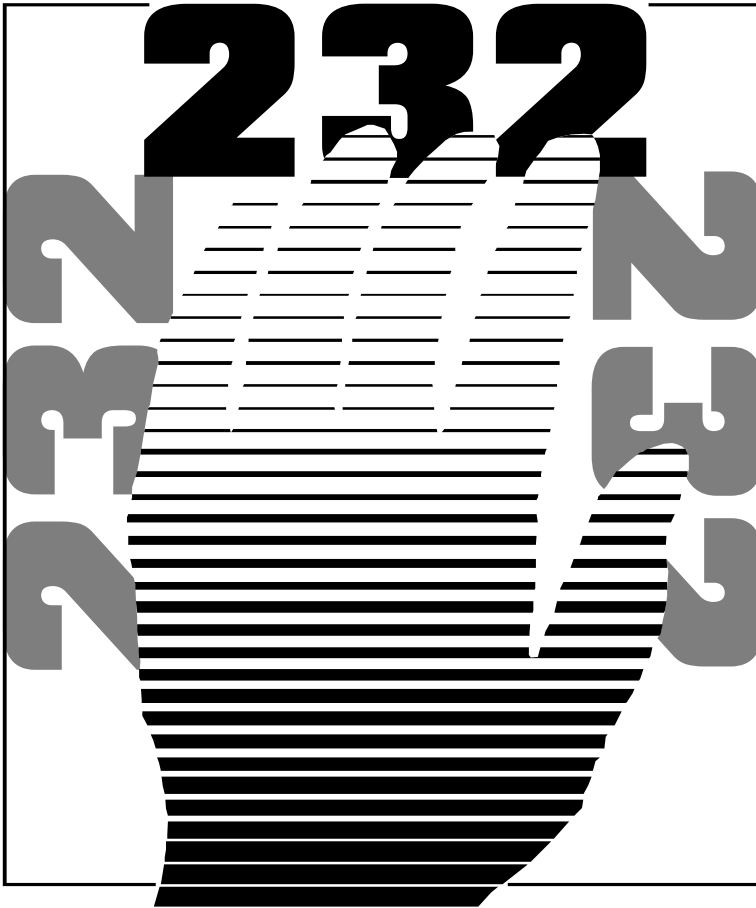

***PCI* Photon**

4 Port RS232

1.0 EDITION December 1998

Guarantee.

FULL 36 MONTHS GUARANTEE.

We guarantee your interface card for a full 36 months from purchase, parts and labour, provided it has been used in the specified manner. In the unlikely event of failure return your interface to your Dealer, with proof of purchase, who will determine whether to repair or replace this product with an equivalent unit.

COPYRIGHT.

COPYRIGHT © 1985-1998.

All rights reserved. No part of this hardware, circuitry or manual may be duplicated, copied, transmitted or reproduced in any way without the prior written consent of the Manufacturer.

Due to the Manufacturers commitment to quality, software is subject to continuous improvements: information regarding upgrades can be obtained from your supplier.

supplied to you by:

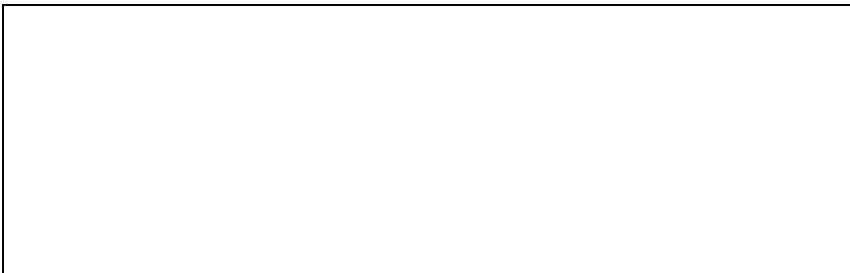

ACKNOWLEDGEMENTS.

IBM, COMPAQ, Hewlett Packard, H.P. and EPSON are trademarks of the relevant companies. Windows is a trademark of Microsoft.

PHOTON 4 PORT RS232 MANUAL

THE LAYOUT OF THIS MANUAL

Chapter 1 - PCI Photon 4 Port RS232 Hardware Configuration, Summarises the features of the PCI Photon 4 Port RS232 Card, describes the two configurable options and lists all the possible DIP Switch options settable on the card.

Chapter 2 – Installing the card into the PC,

Explains how to open the PC and insert a new serial card

Chapter 3 – PCI Photon 4 Port RS232 Software Installation

This chapter details how to install and configure the Photon 4 Port RS232 Card in Windows 3.x, Windows 95/98 and Windows NT.

Chapter 4 – RS232 Port Cabling

Index

PHOTON 4 PORT RS232 MANUAL3

CHAPTER 1 HARDWARE SPECIFICATIONS.....6

 Introduction..... 6

 WARNING For Windows 98 Users Only..... 6

 PCI Photon 4 Port RS232 Card Features..... 6

 PCI Photon 4 Port RS232 Card Specifications..... 7

 Configuring PCI Photon 4 Port RS232 Cards..... 7

CHAPTER 2 INSTALLING THE CARD8

 Serial Card Installation..... 8

 Problems!..... 10

CHAPTER 3 SOFTWARE INSTALLATION 11

 Introduction..... 11

 Configuring Ports In Windows 3.x..... 11

 Determining PCI Photon 4 Port RS232 Resources..... 11

 Serial Solutions Installation for Windows 3.x..... 13

 Serial Port Installation..... 14

 Adding an PCI Photon 4 Port RS232 Serial Card..... 15

 Settings for Photon 4 Port RS232 Card COM1 Present..... 17

 Settings for Photon Card COM1 & 2 Present..... 18

 Settings for Photon Card COM1 to 4 Present..... 19

 Configuring The COM Ports..... 20

 Changing Serial Port Settings..... 20

 Deleting Ports in Windows..... 21

 Restarting Windows..... 21

 Configuring Ports in Windows 95 and 98..... 22

 Windows 95/98 Installation Procedures..... 22

 PCI Photon 4 Port RS232 Card Settings In Win95/98..... 24

 Force Configuration..... 25

 PCI Photon Card Port Settings In Win 95/98..... 26

 Maximum Baud Rate Settings..... 27

 Configuring PCI Photon Ports In Windows NT..... 30

 Software Installation..... 30

 Examining Card Configuration..... 31

PCI Photon 4 Port RS232	Index
Changing Serial Port Settings	32
Advanced Port Settings.....	33
Uninstalling Serial Solutions for Windows NT	35
CHAPTER 4 RS232 PINOUTS AND PORT CABLING.....	36
Introduction.....	36
The RS232 Standard.....	36
Serial Port Pin Outs.....	37
9 Pin D Serial Port Connection To Another PC.....	38
9 Pin D Serial Port To A Modem.....	40
9 Pin D Serial Port Loop Back Connector.....	40
The Photon 4 Port RS232 Cable Pinouts.....	43

CHAPTER 1

HARDWARE SPECIFICATIONS

Introduction.

This chapter details the specifications of the PCI Photon 4 Port RS232 serial card. These half-sized cards will work happily in any PCI 2.0 (or greater) compliant PC compatible.

WARNING For Windows 98 Users Only.

Each PCI Photon 4 Port RS232 Card should be fully installed before adding additional PCI Photon 4 Port RS232 cards.

PCI Photon 4 Port RS232 Card Features.

- * Four independent RS232 Serial ports.
- * Reliable communications up to 50 feet, 15m, and beyond!
- * 100% 16C550 PC Compatible serial port, up to 230,400 baud.
16550 Compatible FIFO provides 128 byte input and 128 byte output buffer on each port.
- * Full modem control TXD, RXD, DSR, DCD, DTR, RTS, CTS and RI signals.
- * Fully double buffered for reliable asynchronous operation.
High speed integrated circuitry ensures operation with fast PC's e.g. 500 MHz Pentium II .
- * Fully PCI 2.1 compliant.
- * Fully Plug and Play
- * Interrupt sharing system allows all ports to use a single interrupt line while preventing any one port from hogging the processor.

Specifications

PCI Photon 4 Port RS232
PCI Photon 4 Port RS232 Card Specifications.

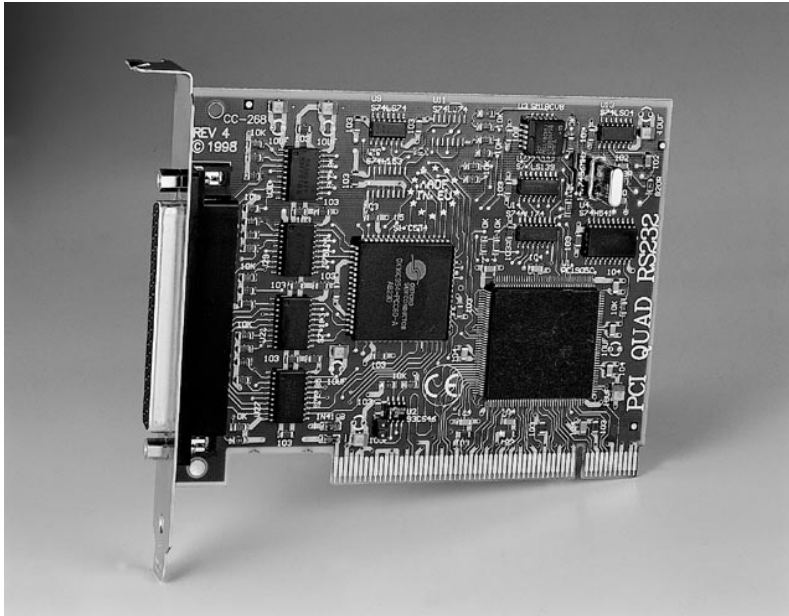

Dimensions: 4.8 x 3.8 in, 120 x 95 mm
I/O Connection: 37 way female D connector
Fully moulded 4 port cable with EITHER 9 or 25 pin D connectors.

Also, refer to Chapter 4 "**RS232 Pinouts and Port Cabling**" for more detailed information on RS232 cabling, ports and pinouts.

Configuring PCI Photon 4 Port RS232 Cards.

The PCI Photon 4 Port RS232 cards are fully “plug and play”, and require no hardware configuration. They can be installed "directly from the box".

CHAPTER 2

INSTALLING THE CARD

Serial Card Installation.

Once the card has been correctly configured then it can be installed in the PC. For the PCI card it is best to make a note of the Bank I/O address and IRQ jumper settings for later use.

After installing the card and configuring the software the cables should be attached and communication with the serial peripheral devices should be established.

Provided that the RS232 installation is attacked in this orderly manner, everything should work first time. If it does not then check the software selectable communications parameters, Baud rate, Parity, stop bits first, and that the communications program is attempting to access the serial port installed. If this fails to solve the problem check the cable connections. Finally check that the card is indeed configured as you believed!

NOTE: Always turn the computer OFF before installing or removing any interface board..!!!

After having made sure that the I/O address and if appropriate jumpers are correctly set, now is the time to insert the PC Serial card into the I/O connector slots in the computer.

STEP 1: Before the PC card can be installed the power to the PC **MUST** be switched **OFF!**

STEP 2: Remove the case.

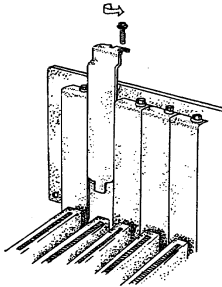
Figure 2-1. Removing Blanking Cover

STEP 3: Choose an empty appropriate expansion slot. Remove the blanking cover protecting the slot on the PC back panel. KEEP the blanking cover screw safely for later (Figure 2-14).

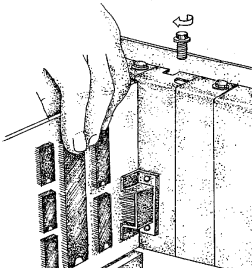
Figure 2-2. Inserting The PC Serial Card.

STEP 4: Now insert the PC Serial card in the available slot. Be careful to ensure that the gold plated PCB fingers fits neatly into the I/O expansion connector. Press down firmly but evenly on the top of the PC Serial card (Figure 2-15).

STEP 5: The D connectors should fit neatly through the slot's aperture to the outside world. NB. Use the screw kept back from the blanking cover to screw the PC Serial retaining bracket into the PC back panel housing.

STEP 6: Now replace the system units cover by carefully sliding it down and back over the system unit. Replace the cover mounting screws.

Attach all the cables.

The PC should power on in the normal way.

If the system fails to power up normally check the following:

- i.) Ensure that the PC Serial card is installed correctly.
- ii.) Ensure that other cards in the PC have not been upset.
- iii.) Ensure that the power is connected and the PC is switched ON!

■ If all these have been checked and the PC still does not power up then there is probably a conflict of I/O address between the PC Serial card and another board in the PC. Ask your dealer to check this

CHAPTER 3**SOFTWARE INSTALLATION****Introduction.**

This section describes the software installation procedure allowing the PCI Photon 4 Port RS232 to be configured within the Windows 3.x, Windows 95/98 and Windows NT operating systems.

Configuring Ports In Windows 3.x

The Windows 3.x installation procedure consists of 3 steps:

1. Insert the PCI Photon 4 Port RS232 Card into a free PCI slot and power up the PC.
2. Determine the resources that the PCI Photon 4 Port RS232 has claimed.
3. Inform Windows 3.x of those resources.

Determining PCI Photon 4 Port RS232 Resources.

- Insert the card into a PC, as described in Chapter 2, power up the PC
- From DOS Run BBCARDS.EXE, Found on the HandyWEB CDROM, by typing the following:

```
<drive:>\drivers\speed\win31\bbcards
```

Where <drive>is the drive containing the supplied disk.

BBCARDS.EXE will display a message that looks similar to the following (the values displayed may differ due to resource availability):

PCI Photon 4 Port RS232 Users:

card 1 is on bus 0, device 16, function 0
Card ID=2, revision 3: Photon 4 Port RS232
interrupt line IRQ11 has been assigned
4 sets of 16550-compatible registers are at Bank I/O address FF40
SISR is at I/O address FFA0
Baud clock control is at I/O address FFC0
Write 0xf6 for /8 (default), 0xf2 for /4, 0xd6 for /2, 0xd2 for /1.

Note the IRQ, I/O address and SISR Address values

In our example:

The IRQ = 11

The IRQ is the interrupt line shared amongst the Photon 4 Port RS232 card's serial ports

The Bank address = FF40

The Bank address determines the COM Port Base addresses in the following manner:

COM Base of port 1 = the Bank Address

COM Base of port 2 = the Bank Address + 8hex

COM Base of port 3 = the Bank Address + 10hex

COM Base of port 4 = the Bank Address + 18hex

The SISR Address = FFA0

The SISR Address is the Shared Interrupt Status Register, this is a read-only register indicating which of the four serial ports requires service by the driver software.

PCI Photon 4 Port RS232 Serial Solutions Installation for Windows 3.x

Software Installation

To install the software from the supplied disk, insert the disk, from Windows **Program Manager's** File menu choose "Run" and in the Command Line entry window type <drive:>\disking\sswin3x\setup.exe (CDROM) or <drive:>\setup.exe (FLOPPY) (where <drive:> is the path to installation disk).

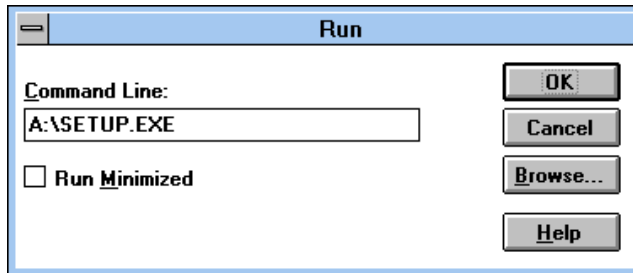

Selecting the "OK" button shows the setup program main screen, Figure 4-1, which will automatically select components for installation that have not already been installed. Selecting the "Del All" button will select all installed components for deletion and selecting "Add All" chooses all uninstalled components for installation. Several of the components have user selectable parameters, e.g. target install directory, which can be changed by clicking on the button. These options may not be changed once the components have been installed. A README.TXT file on the disk contains details of the latest updates to this software,

Note: If it is necessary to re-install an OLDER version of a component then the NEWER version component must be FIRST removed by selecting the component's button in the "Uninstall" column then selecting the "Continue" button.

If only logical ports COM1 to COM9 are to be used then de-select the Comms API library option button in the "Install" column. This library is only necessary to allow the use of logical ports greater than COM9 e.g. COM10, COM11 etc.

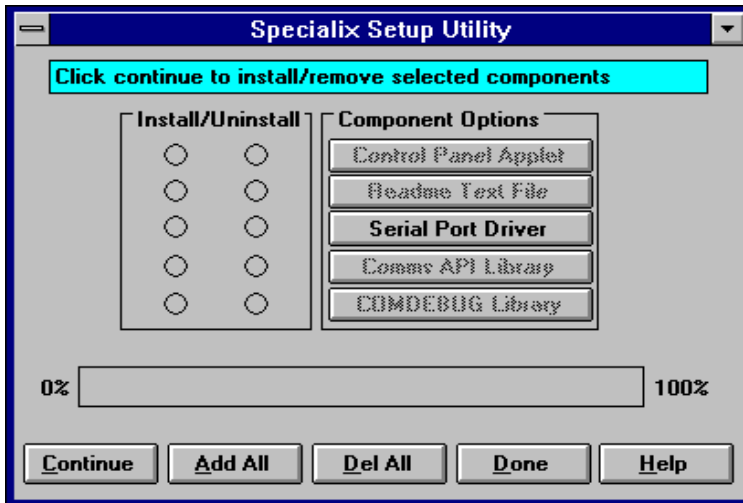
Figure 3-1. Setup Program Main Display.

Selecting the **Continue** button will start the installation process. When the setup program has finished select the **Done** button. A Windows restart message will be shown only if the Windows communications driver option has been selected, and you should choose **Yes** to allow the new driver to run.

Serial Port Installation.

- From **Main**, select **Control Panel**:



- Click on **Serial Ports**:

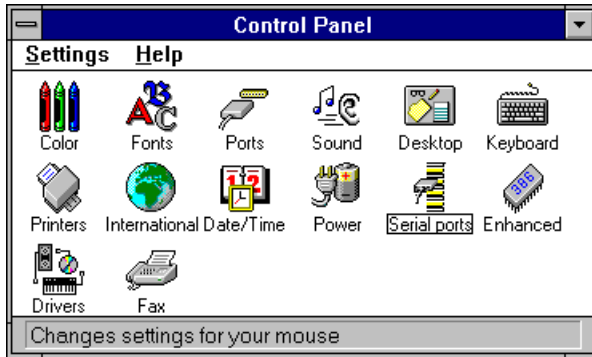

The following dialogue will be displayed:

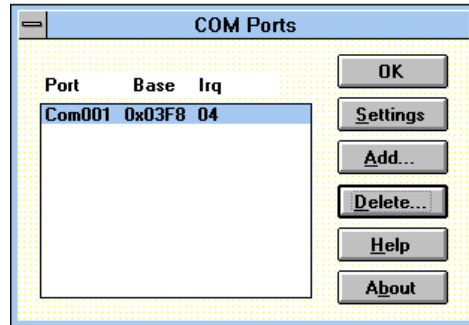

Adding an PCI Photon 4 Port RS232 Serial Card.

For each port on the Photon 4 Port RS232 card we need to **ADD** a port and fill in the following 7 settings in the order given. Default values for the communications settings are given whenever the ADD button is used, 9600 baud, no parity, 8 data bits and 1 stop bit.

Figure 3-2. PCI Photon 4 Port RS232 Serial Card Settings.

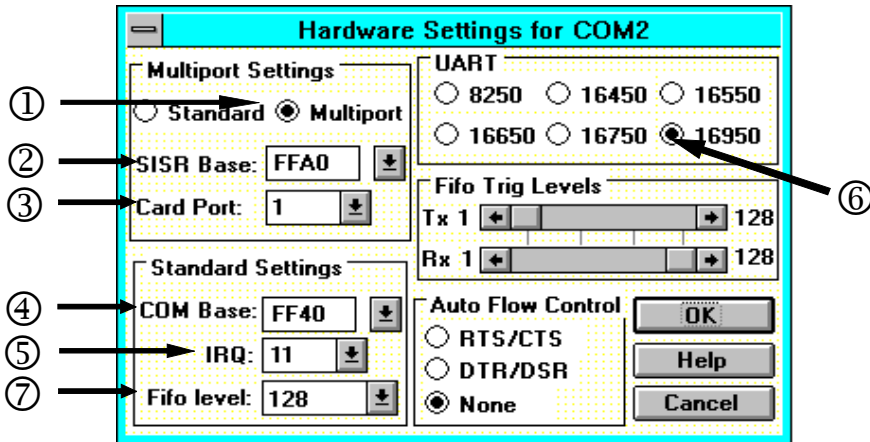

Multiport Settings:-

① Each Port should have the **Multiport** button selected, this tells Windows 3.x that the port is one of several ports using a SISR (shared interrupt status register).

② The **SISR Base** address must be set as indicated by the BBCARDS program.

③ The **Card Port** setting tells Windows whether this is the first, second, third or fourth port of the Photon 4 Port RS232 card.

Standard Settings:-

④ The **COM Base** is determined from the Bank Address as described above, P63.

⑤ The **IRQ** must be set as indicated by the BBCARDS program.

⑥ The **UART** on the photon port is an enhanced 16550 called the 16950.

⑦ Having selected the 16950 you can then set the **FIFO level** at 128 bytes.

PCI Photon 4 Port RS232 Software Installation

Settings for Photon 4 Port RS232 Card COM1 Present

COM Port	SISR	Card Port	COM Base	IRQ	UART	FIFO Trip
BBCARDS Values *	FFA0		FF40	11		
COM2	FFA0	1	FF40	11	16950	Default
COM3	FFA0	2	FF48	11	16950	Default
COM4	FFA0	3	FF50	11	16950	Default
COM5	FFA0	4	FF58	11	16950	Default

*The BBCARDS Values may be different from your machine.

Card Port 1

Hardware Settings for COM2

Multiport Settings
 Standard Multiport
 SISR Base: FFA0
 Card Port: 1

UART
 8250 16450 16550
 16650 16750 16950

Fifo Trig Levels
 Tx 1: 128
 Rx 1: 128

Standard Settings
 COM Base: FF40
 IRQ: 11
 Fifo level: 128

Auto Flow Control
 RTS/CTS
 DTR/DSR
 None

OK Help Cancel

Card Port 2

Hardware Settings for COM3

Multiport Settings
 Standard Multiport
 SISR Base: FFA0
 Card Port: 2

UART
 8250 16450 16550
 16650 16750 16950

Fifo Trig Levels
 Tx 1: 128
 Rx 1: 128

Standard Settings
 COM Base: FF48
 IRQ: 11
 Fifo level: 128

Auto Flow Control
 RTS/CTS
 DTR/DSR
 None

OK Help Cancel

Card Port 3

Hardware Settings for COM4

Multiport Settings
 Standard Multiport
 SISR Base: FFA0
 Card Port: 3

UART
 8250 16450 16550
 16650 16750 16950

Fifo Trig Levels
 Tx 1: 128
 Rx 1: 128

Standard Settings
 COM Base: FF50
 IRQ: 11
 Fifo level: 128

Auto Flow Control
 RTS/CTS
 DTR/DSR
 None

OK Help Cancel

Card Port 4

Hardware Settings for COM5

Multiport Settings
 Standard Multiport
 SISR Base: FFA0
 Card Port: 4

UART
 8250 16450 16550
 16650 16750 16950

Fifo Trig Levels
 Tx 1: 128
 Rx 1: 128

Standard Settings
 COM Base: FF58
 IRQ: 11
 Fifo level: 128

Auto Flow Control
 RTS/CTS
 DTR/DSR
 None

OK Help Cancel

NOTE: The only settings that change from port to port are the COM Base and the Card Port Settings

Settings for Photon Card COM1 & 2 Present

COM Port	SISR	Card Port	COM Base	IRQ	UART	FIFO Trip
BBCARDS Values*	FF80		FFC0	10		
COM3	FF80	1	FFC0	10	16950	Default
COM4	FF80	2	FFC8	10	16950	Default
COM5	FF80	3	FFD0	10	16950	Default
COM6	FF80	4	FFD8	10	16950	Default

*The BBCARDS Values may be different from your machine.

Card Port 1

Card Port 2

Card Port 3

Card Port 4

NOTE: The only settings that change from port to port are the COM Base and the Card Port Settings

PCI Photon 4 Port RS232 Software Installation

Settings for Photon Card COM1 to 4 Present

COM Port	SISR	Card Port	COM Base	IRQ	UART	FIFO Trip
BBCARDS Values*	FFE0		FFC0	5		
COM5	FFE0	1	FFC0	5	16950	Default
COM6	FFE0	2	FFC8	5	16950	Default
COM7	FFE0	3	FFD0	5	16950	Default
COM8	FFE0	4	FFD8	5	16950	Default

*The BBCARDS Values may be different from your machine.

Card Port 1

Hardware Settings for COM5

Multiport Settings: Standard Multiport

SISR Base: FFE0

Card Port: 1

UART: 8250 16450 16550
 16650 16750 16950

Fifo Trig Levels: Tx 1: 128, Rx 1: 128

Standard Settings: COM Base: FFC0, IRQ: 5, Fifo level: 128

Auto Flow Control: RTS/CTS DTR/DSR None

Buttons: OK, Help, Cancel

Card Port 2

Hardware Settings for COM6

Multiport Settings: Standard Multiport

SISR Base: FFE0

Card Port: 2

UART: 8250 16450 16550
 16650 16750 16950

Fifo Trig Levels: Tx 1: 128, Rx 1: 128

Standard Settings: COM Base: FFC8, IRQ: 5, Fifo level: 128

Auto Flow Control: RTS/CTS DTR/DSR None

Buttons: OK, Help, Cancel

Card Port 3

Hardware Settings for COM7

Multiport Settings: Standard Multiport

SISR Base: FFE0

Card Port: 3

UART: 8250 16450 16550
 16650 16750 16950

Fifo Trig Levels: Tx 1: 128, Rx 1: 128

Standard Settings: COM Base: FFD0, IRQ: 5, Fifo level: 128

Auto Flow Control: RTS/CTS DTR/DSR None

Buttons: OK, Help, Cancel

Card Port 4

Hardware Settings for COM8

Multiport Settings: Standard Multiport

SISR Base: FFE0

Card Port: 4

UART: 8250 16450 16550
 16650 16750 16950

Fifo Trig Levels: Tx 1: 128, Rx 1: 128

Standard Settings: COM Base: FFD8, IRQ: 5, Fifo level: 128

Auto Flow Control: RTS/CTS DTR/DSR None

Buttons: OK, Help, Cancel

NOTE: The only settings that change from port to port are the COM Base and the Card Port Settings

PCI Photon 4 Port RS232

Software Installation

Select the **OK** button to finish adding the port. This will display a Windows restart message, but do not restart until you have installed all four ports. Be sure to restart Windows after all serial ports have been added so that the new configuration takes effect.

Figure 3-3. After Adding a PHOTON Card (COM1 present).

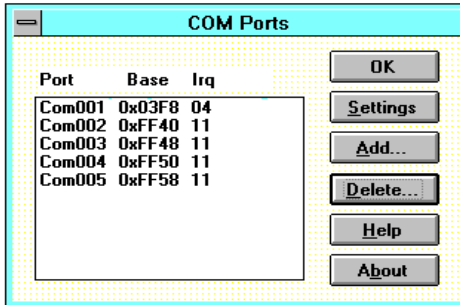

Note: Adding a port automatically sets default values for the communications settings to 9600 baud, no parity, 8 data bits and 1 stop bit. These values can be changed as described below.

Configuring The COM Ports.

Figure 3-4 PCI Photon Card Comms Settings

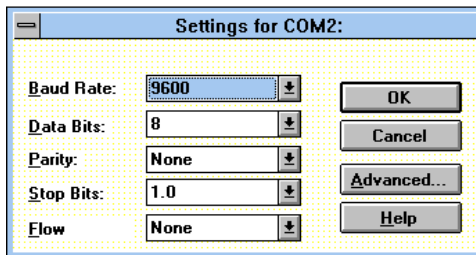

Changing Serial Port Settings

Once the Photon 4 Port RS232 card has been installed it may be necessary to change the communications settings in the COM Ports to match the baud rate, parity settings etc. of the remote serial device.

PCI Photon 4 Port RS232

Software Installation

- Highlight the serial port required, e.g. COM2., in Serial Ports, Control Panel
- Click on the **Settings** button to change the communications settings, Figure 3-3.
- Select the appropriate communications settings, which must match the communications settings on the remote device.
- Click on the **OK** button to leave the communications **Settings** window.

The **Advanced** option in **Settings** can be used to change the hardware settings to match a new base address and IRQ because the PC's BIOS has reallocated the PCI resources due to the installation of other new hardware.

- Click on the **Advanced** button for the hardware settings window, Figure 3-4. Enter the 7 options in the same manner as described in the section "Adding a PCI Photon 4 Port RS232 Serial Card"

Deleting Ports in Windows.

The **Delete** button can be used to discard the entries of ports that have been removed from the system.

Note. Due to problems with the standard Windows Serial Ports Applet in the Control Panel **Make sure** that there are no gaps in the numbering of the first four serial ports, COM 1-4. If necessary leave a "place holder" otherwise Windows may automatically reorder the COM port numbers resulting in serious problems.

Restarting Windows.

Whenever certain values have been changed in the **Advanced** window, a message prompting the user to restart Windows will appear. Once ALL necessary changes have been made Windows should be restarted so that the new settings may come into effect.

PCI Photon 4 Port RS232 **Software Installation** **Configuring Ports in Windows 95 and 98.**

Although covering the installation of the PCI Photon 4 Port RS232 cards into the Windows 95 operating system. The Windows 95 environment now supports up to 255 standard serial ports.

Windows 98

The Windows 98 operating system procedure is the same as for Windows 95 with only minor differences. The only significant difference is that only one PCI Photon Card should be added to the PC per boot. E.g. if three PCI Photon cards are to be installed then the whole of the following procedure needs to be carried out three times.

Windows 95/98 Installation Procedures

- Insert the card in a free PCI slot, power up the PC.
- Windows 95 should then load normally. During the booting process, Windows 95 will detect the card and briefly display a message box indicating the detection process.
- Windows will then display the "Update Device Driver Wizard", requesting "insert any disk which came with the PCI card". Insert the Serial Solutions CDROM installation disk into an appropriate drive and click 'Next' and follow the path laid out below.

Figure 3-5 PCI Photon Card Comms Settings

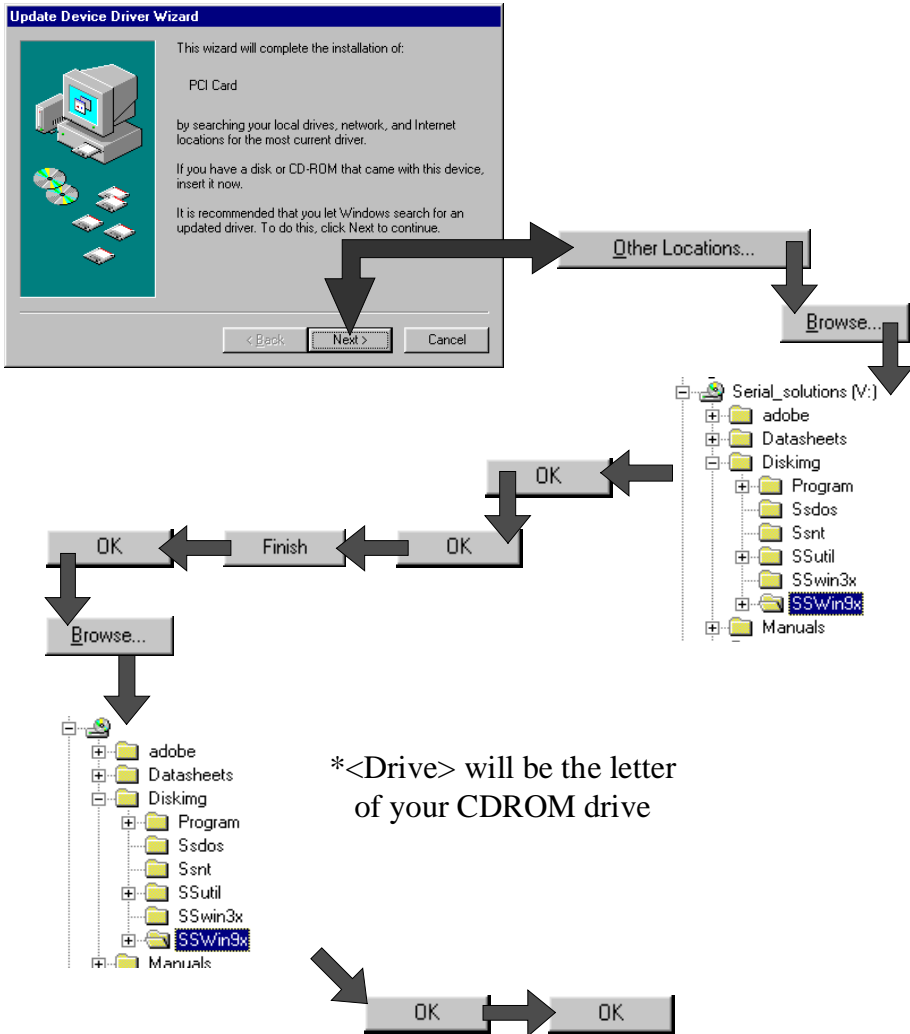

*<Drive> will be the letter of your CDROM drive

If you are installing from a floppy disk click **Next** and the software will be found on the floppy disk and installed.

PCI Photon 4 Port RS232

Software Installation

- After copying the files Windows 95 will then detect each of the serial ports in turn and install them as Photon 4 Port RS232 communications ports.

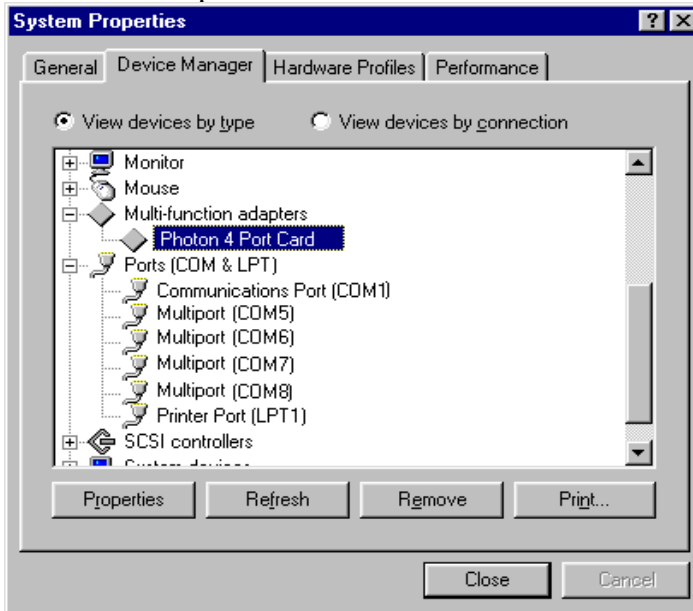

The **Device Manager**, reached by clicking on 'System' in the Control Panel, now shows the presence of the PCI Photon 4 Port RS232 Card under **Multi-function adapters**. See below.

If there are no other serial port cards installed above COM 4, the PCI Photon 4 Port RS232 will appear as COM5 -COM8. If there already are more than 5 COM ports installed the Multiport card ports will appear as the next highest available COM ports. PCI Photon Cards do not appear with the COM1 to COM4 assignment since these ports are reserved for legacy PCI cards.

PCI Photon 4 Port RS232 Card Settings In Win95/98.

- Double clicking a card entry under the "**Multi-Function Adapters**", in **Device Manager** will display general properties for the selected card.

- Clicking on the **Serial Solutions** tab will display:

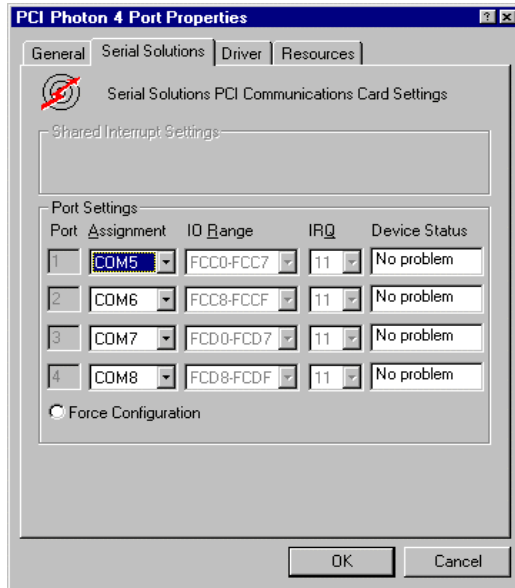

Some communications applications require the serial ports they access to be as named COM 4 or lower. The COM port assignment may be changed, simply by selecting a new COM port value from the pull down menu relevant to the port. However, COM port usage other than those for the selected card itself are not checked, so it is advisable to first check which COM ports are in use - port availability can be checked by viewing the **Device Manager**:

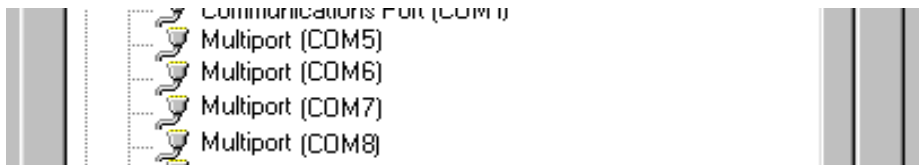

Force Configuration

This allows the user to select particular In/Out Address for one or more ports. This is only necessary when running applications in the DOS box that access ports at hard coded addresses.

All COM ports present will be listed under the entry "Ports (COM & LPT)." The above screenshot indicates that COM9 and above are not installed.

PCI Photon Card Port Settings In Win 95/98.

Double clicking upon an individual port entry in the **Device Manager**, and selecting the **Port Settings** tab will display:

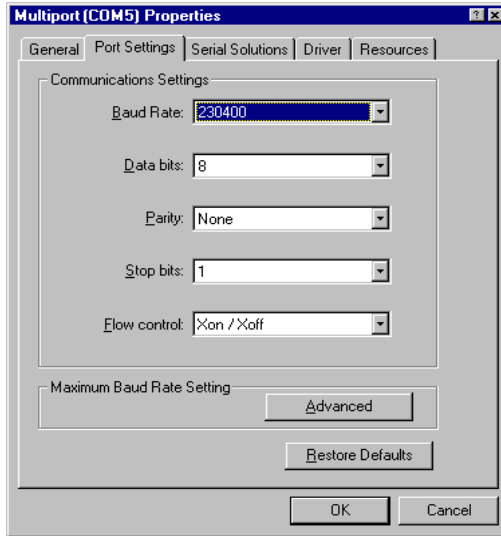

Settings available in this window are:

- 1. **Baud Rate.**
 - 2. **Data Bits.**
 - 3. **Parity.**
 - 4. **Stop Bits.**
 - 5. **Flow Control.**
- } Change to suit remote device.
- 6. **Restore Defaults** - When clicked, this will reset the selected port to the default values of:

Baud Rate:	9600
Data Bits:	8
Parity:	None
Stop Bits:	1
Flow Control:	Xon / Xoff

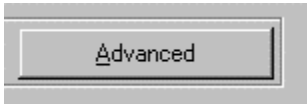

Clicking the **Advanced** button gives the user the option of changing the behaviour of the driver.

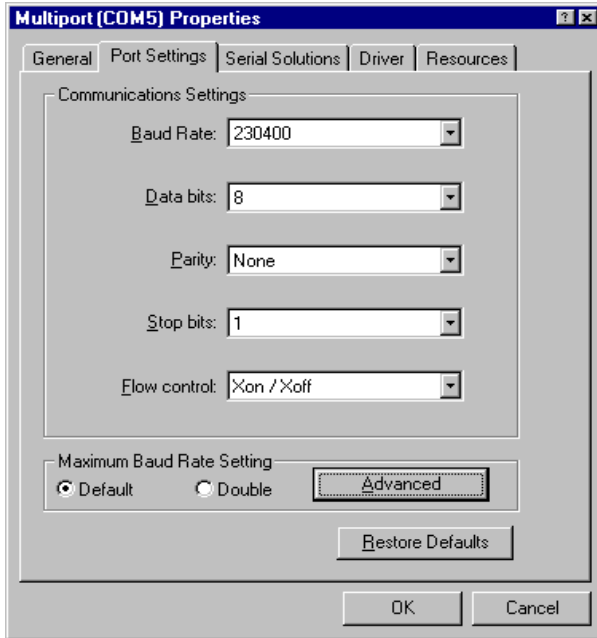

The **Default** behaviour of the driver is to operate on a wysiwyg (what you see is what you get) basis, meaning the Baud rate than application selects will be the Baud rate of the data leaving the port.

Selecting **Double** changes the driver behaviour in the following ways...

For applications using the above dialogue e.g. HyperTerminal there will be no change.

For applications directly calling the Win32 API e.g. Dial Up

Networking the selected baud rate is doubled, i.e. selecting 115,200 gives a real baud rate of 230,400.

Selecting the **Serial Solutions** tab of the selected port properties Window will display:

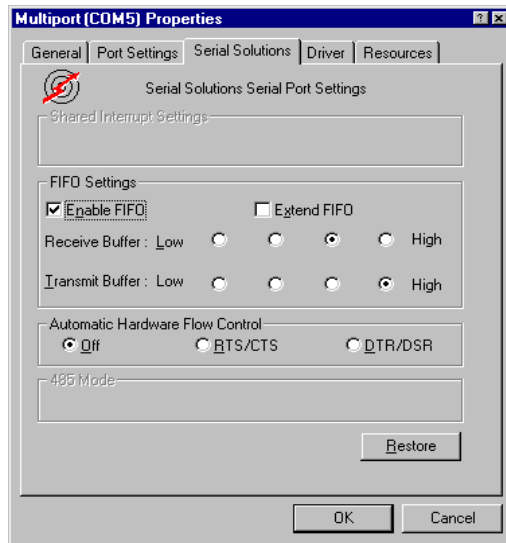

Settings available in this window are:

1. FIFO settings.

- **Enable FIFO** - turns the selected ports FIFO buffer on or off. It is strongly recommended that the FIFO for all ports is left enabled.
- **Extend FIFO** – When the FIFO is enabled the default FIFO size is 16 Bytes. The extended FIFO size is 128 Bytes.
- **Receive Buffer** - These settings allow the selection of a receiver FIFO trigger setting. Selecting a low value will allow the interrupt to be serviced quicker, which is good for slow machines. If you have a fast machine, setting a high value will give you more time for multi-tasking operations. The trigger options in the case of the Photon Card's 128 byte FIFO are 1, 32, 64 and 112.

- **Transmit Buffer** - These settings allow the selection of a transmitter FIFO trigger setting. Selecting a low value will send fewer data-bytes per interrupt, and this is recommended if you are communicating to a slower machine. Selecting a high value will send more data-bytes per interrupt, and will give more time for multi-tasking operations. The trigger options in the case of the Photon Card's 128 byte FIFO are 1, 32, 64 and 112.

2. **Restore-**

Clicking on this port will restore the port setting of the Serial Solutions tab to the values set on entry to this page.

Configuring PCI Photon Ports In Windows NT.

Microsoft Windows NT Provides built in support for 255 standard serial ports. To setup your PCI Photon 4 Port RS232 serial card you should follow these steps. Please note that to change any kind of hardware configuration under Windows NT you must be logged in as a user with Administrator level privileges, if you do not have these please contact your system administrator.

Software Installation.

Insert the PCI Photon 4 Port RS232 Card into your PC, as described in chapter 2, and restart. Place the supplied Serial Solutions CDROM in a suitable drive and from the Start Menu choose Run and enter the path Below. If you are installing from floppy disk the path will be <drive:>\setup.exe. (where <drive:> is the path to the drive containing the installation disk).

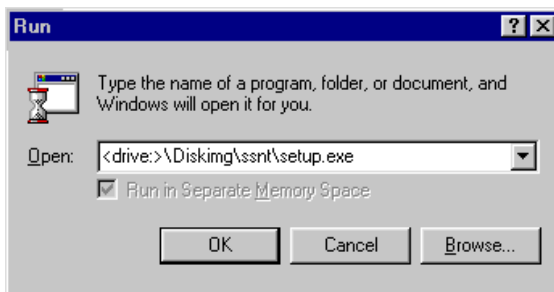

Selecting the "OK" button begins the conventional InstallShield setup process, there are no options for this installation, all items must be installed in the NT System32 directory. Once the software has been installed, you may run the **Serial Solution** applet by double clicking on it's icon from the **Control Panel**.

- InstallShield will then install the driver software automatically - it will then copy the necessary files and start itself. This automatically detects your new PCI serial card(s) and does not require any further system restarting.

PCI Photon 4 Port RS232 Examining Card Configuration.

Software Installation

Go to Control Panel (Start Menu/Settings/Control Panel) and double click on Serial Solutions:



After adding a Photon 4 Port RS232 Card (COM 1 present) you will be presented with a Serial Solutions Port Configuration window:

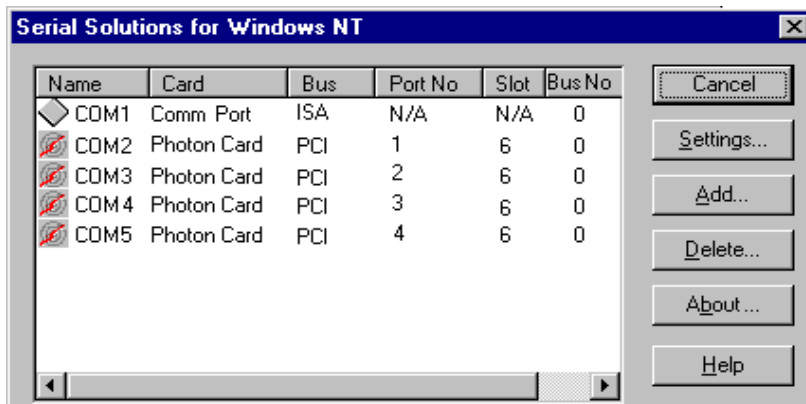

Changing Serial Port Settings

Adding a Photon 4 Port RS232 Card to the system automatically sets default values for communications settings to 9600 Baud, 8 Data Bits, No Parity and 1 Stop Bit.

To view the settings of a port, select it and click on **Settings**. Clicking on the **Port Settings** tab opens up the following window:

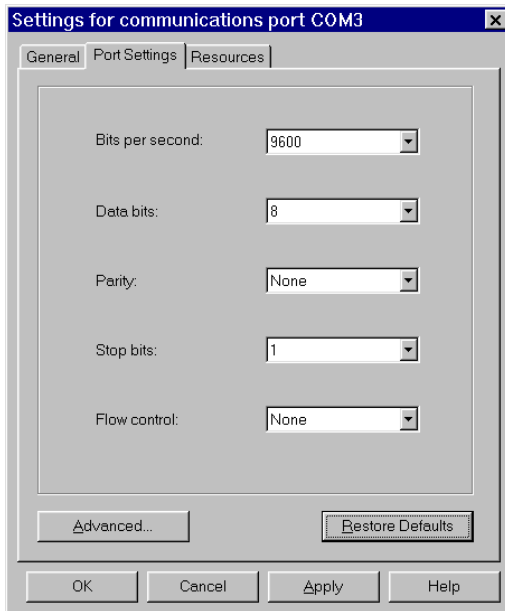

Settings available in this window are:

1. **Baud Rate** - determines the baud rate at which the selected port operates, providing it is not overridden by any serial comms applications in use. PCI Photon 4 Port RS232 will operate correctly up to 230,400 baud at distances of up to 10 meters,

Note: Many serial comms applications will not actually register the ports as running at baud rates of above 115200.

2. **Data Bits.**
 3. **Parity.**
 4. **Stop Bits.**
 5. **Flow Control.**
- } Change to suit remote device.

6. **Advanced** - see the section below, titled "**Advanced Port Settings.**"

7. **Restore Defaults** - when clicked, resets the selected COM port to the following values:

Baud Rate:	9600
Data Bits:	8
Parity:	None
Stop Bits:	1
Flow Control:	Hardware

Advanced Port Settings.

When the **Advanced** button of Port Settings is selected the following dialogue is displayed:

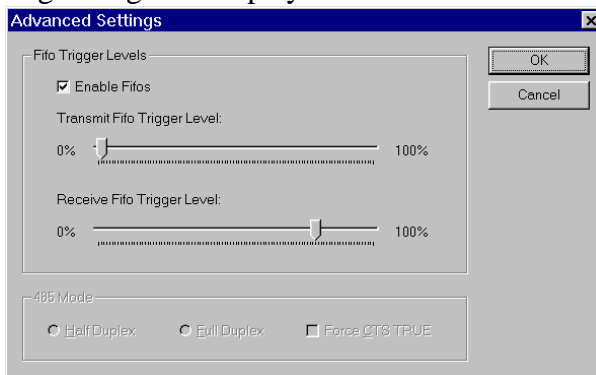

Settings available in this window are:

1. **FIFO settings.**

- **Use FIFO Buffers** - turns the selected ports FIFO buffer on or off. It is strongly recommended that the FIFO for both ports is left enabled.
- **Receive Buffer** - These settings allow the selection of a receiver FIFO trigger setting. Selecting a low value will lessen the likelihood of data loss due to overrun errors when Photon 4 Port RS232 cards are installed in slower host PCs running ports at higher baud rates. Setting a high value will give better

overall system performance when the host PC has multiple applications running simultaneously.

- **Transmit Buffer** - These settings allow the selection of a transmitter FIFO trigger setting. Selecting a low value will send fewer data-bytes per interrupt, this is recommended if you are communicating to an older external serial device. Setting a high value will give better overall system performance when the host PC has multiple applications running simultaneously.

Be warned, many older devices or even modern PC's without PHOTON ports cannot deal with long bursts of data, especially at high Baud rates.

2. **Defaults** - When clicked this button resets the advanced properties to the followed settings:

Use FIFO Buffers:	On (checked)
Transmit Buffers:	1%
Receive Buffers:	80%

PCI Photon 4 Port RS232 Software Installation

Uninstalling Serial Solutions for Windows NT

To uninstall Serial Solutions for Windows NT:

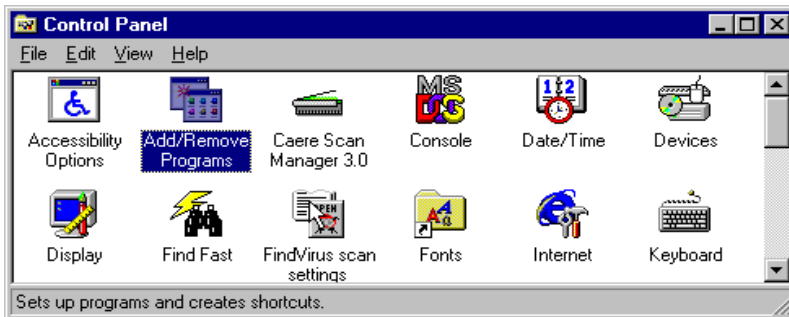

- From Control Panel, open the **Add/Remove** Programs applet, then be certain to close the Control Panel.

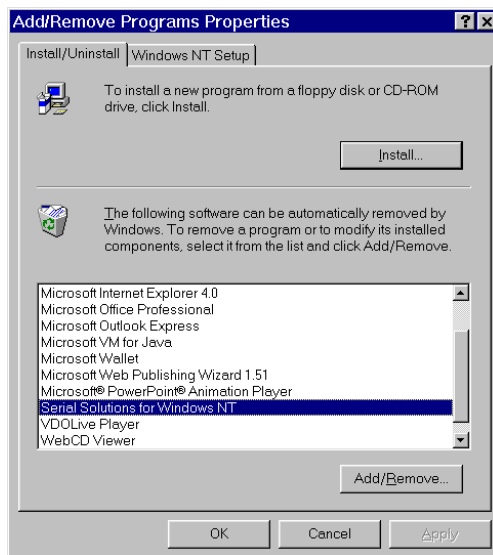

- Select from the list **Serial Solutions for Windows NT**.
- Click the **Add/Remove** button.

Windows NT will then uninstall the Serial Solutions applet, without the need for restarting your machine.

CHAPTER 4 RS232 PINOUTS AND PORT CABLING.

Introduction.

This chapter gives details of the 9 and 25 pin RS232 pin outs, cabling and connections, with information on how to connect the serial ports of two PCs, how to make a selftest loop back connector and the pinouts of the Photon 4 Port RS232 cards.

The RS232 Standard.

The RS232 standard is ancient in computer industry terms. Introduced in 1962, it is now widely established. RS232 is a slow photon, short distance, single ended transmission system (i.e. only one wire per signal). Typical RS232 maximum cable length is 50 feet with a maximum data rate of 20K bits per second.

Figure 4-1. RS232 Point To Point Connection.



RS232C Standard	
1 Driver 1 Receiver	
Line Length	Max Data Rate
50 Feet = 15m	20 Kbits/sec

The pinouts of the 9 & 25 pin Male D connectors are given below.

Figure 5-2. Serial Port RS232 Pin Outs.

9 Pin connector:

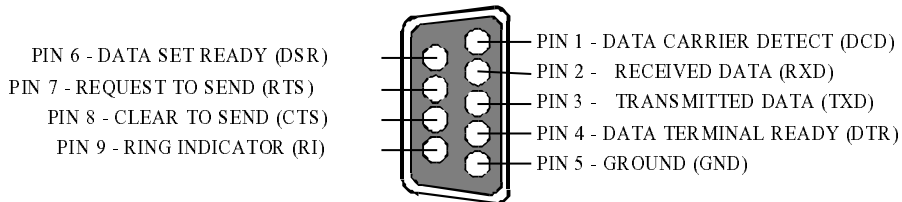

25 Pin connector:

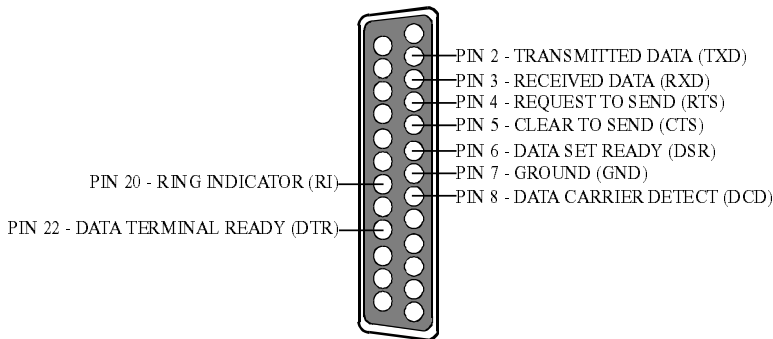

9 Pin D Serial Port RS232 Cables.

To connect to the AT style RS232 Serial Port you will need a cable terminating in a 9 way female D connector. It is sound practice to use cables with screws fitted that will allow you to fasten the cable securely to the PC card.

In general, you will need to make up a "cross over" cable to correctly interface the PC to the RS232 port of another computer or device. Traditionally, making up the cross over cable has been considered a black art. However, provided you have the pin outs

and handshake requirements of both sides of your RS232 connection, the cross over cable becomes a matter of common sense. The cross over cable is simply to ensure that the right signals going out of one RS232 port go into the appropriate lines of the other RS232 port.

9 Pin D Serial Port Connection To Another PC.

Suppose we want to connect the AT style 9 pin D Serial Port to the serial port of another IBM PC 25 pin D. See Figure 6-3.

- 1) Connect the earth lines.
Line 5 of Serial Port 2 to lines 1 & 7 of the other PC.
This gives the two devices a common earth level.
- 2) Connect the Transmit and Receive lines together.
Line 3, TXD, Port 2 goes to line 3, RXD, of the other PC.
Line 2, RXD, Port 2 goes to line 2, TXD, of the other PC.
This allows each to receive the data transmitted by the other.
- 3) Connect the Port 2 DTR line, pin 4 to the other PC DCD, pin 8 and CTS, pin 5, lines.
Also, connect up the other PC DTR line, pin 20 to the Port 2 DCD, pin 1 and CTS, pin 8, lines.
This allows the receiving device to signal when it can no longer accept data. The receiving device sets DTR false when it is unable to receive any more data. The sending device reads DTR on its CTS and DCD pins. It should stop sending when CTS goes false.
- 4) Connect the Port 2 RTS line, pin 7, to the other PC DSR line, pin 6.
Also, connect the other PC RTS line, pin 4, to the Port 2 DSR line, pin 6. This RTS line is used to let the other device know that it is ready for data exchange.

Figure 4-3. 9 Pin D Serial Port To Other PC Cable.

AT SERIAL PORT Side
Side.

Other PC SERIAL PORT

9 PIN D CONNECTOR

9 PIN D CONNECTOR

SCHEMATIC REPRESENTATION:

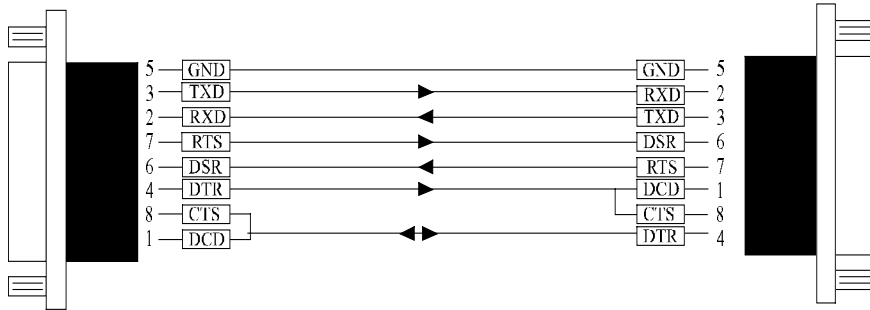

ACTUAL REPRESENTATION:

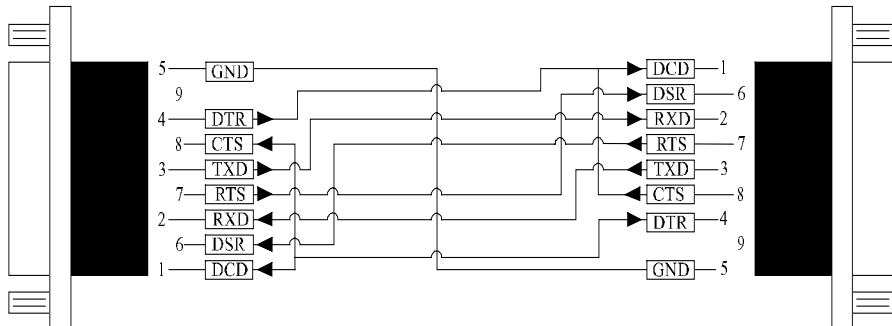

PCI Photon 4 Port RS232
9 PIN D CONNECTOR

RS232 Pinouts and Cabling
25 PIN D CONNECTOR

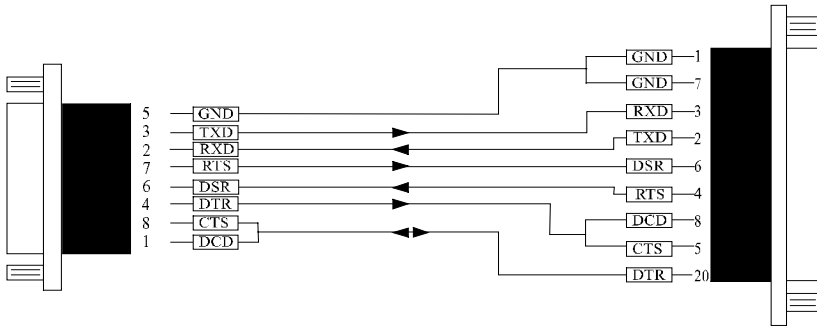

ACTUAL REPRESENTATION

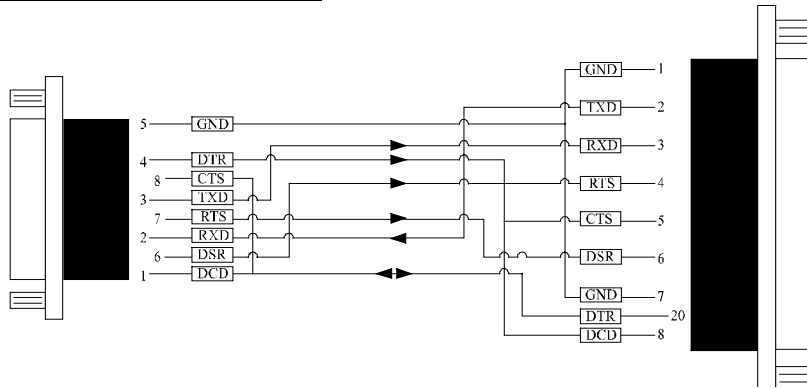

9 Pin D Serial Port To A Modem.

If you are connecting a MODEM to a 9 pin D Serial Port then you will NOT need a cross over cable and a straight through cable connected as the 9 to 25 pin adapter given in Figure 4-5.

9 Pin D Serial Port Loop Back Connector.

A loop back connector can be used to echo RS232 data transmitted by a serial port back into its own RS232 receiver. In this way, the function of the serial port can be tested.

For an AT style Serial Port use the a female 9 way connector wired as in Figure 4-4.

Figure 4-4. 9 Pin D Serial Loop Back Connector.

9 PIN D CONNECTOR

25 PIN D CONNECTOR

SCHEMATIC REPRESENTATION:

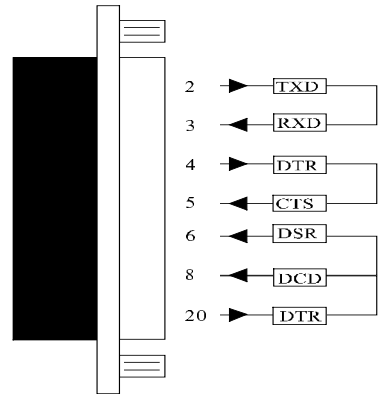
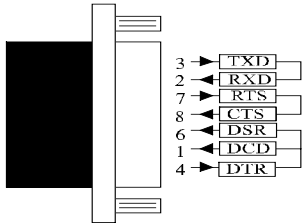

ACTUAL REPRESENTATION:

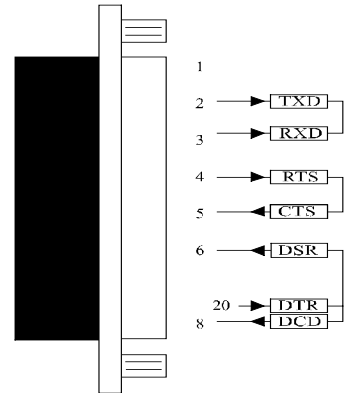
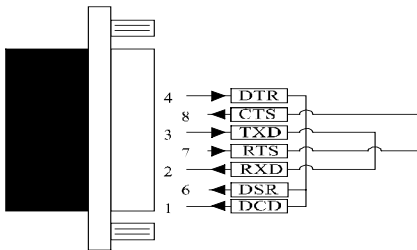

Figure 6-5. 9 To 25 Way Adapter.

This adapter cable makes the AT style 9 pin serial port, look like the standard PC 25 pin serial port. It is NOT a cross over cable!

9 Pin AT SERIAL PORT

9 Pin Female D Connector

25 Pin PC SERIAL PORT

25 Pin Male D Connector

SCHEMATIC REPRESENTATION

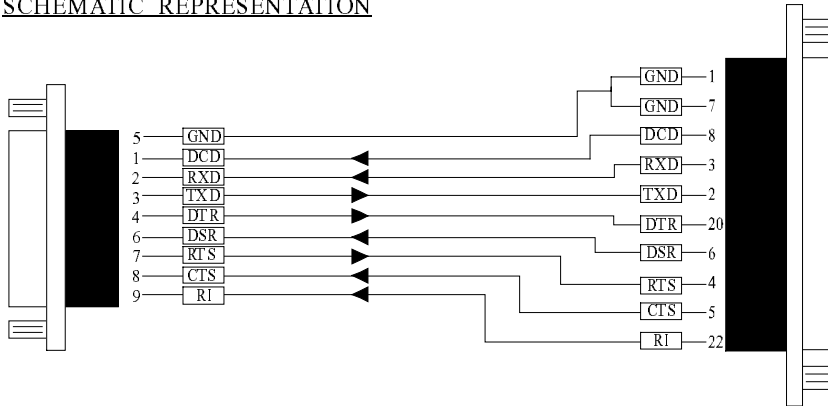

ACTUAL REPRESENTATION

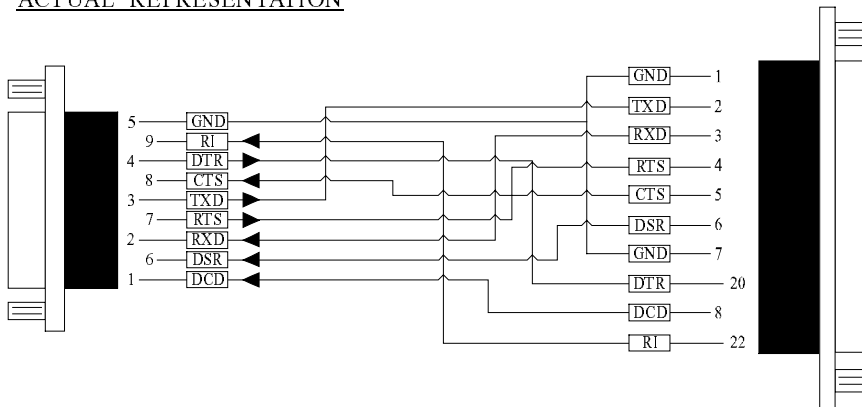

PCI Photon 4 Port RS232 RS232 Pinouts and Cabling

The Photon 4 Port RS232 Cable Pinouts

The Photon 4 Port RS232 cable consists of a 37 way female D connector attached to four either 25 or 9 way Male D connectors. Each of the cables carries 9 cores plus a sheath. Each of the 25 pin D connectors has 9 connections, based on the standard PC serial port configuration. Figure 4-7, on the next page shows the 37 way female connector pin numbers corresponding to each of the 4 separate port pin outs and pin functions. Each cable is approximately 1 metre long and is clearly marked as P1 for Port 1, P2 for Port 2 etc.

Figure 4-6. Photon 4 Port RS232 Cable by 9 & 25 pin D Connector

37 way D connector Pinouts						
Port #1	Port #2	Port #3	Port #4	Pin Function	9 Pin	25 Pin
3	26	12	35	Transmitted Data (TXD)	3	2
2	25	11	34	Received Data (RXD)	2	3
21	7	30	16	Request To Send (RTS)	7	4
22	8	31	17	Clear To Send (CTS)	8	5
20	6	29	15	Data Set Ready (DSR)	6	6
5	28	14	37	Ground (GND)	5	7
1	24	10	33	DataCarrier detect(DCD)	1	8
4	27	13	36	Data terminal Ready (DTR)	4	20
23	9	32	18	Ring Indicator (RI)	9	22

NOTE: Pin 19 on the 37 pin D connector is not used.

Figure 4-7. Pin outs of the PCI Photon 4 Port RS232 37 pin D connector

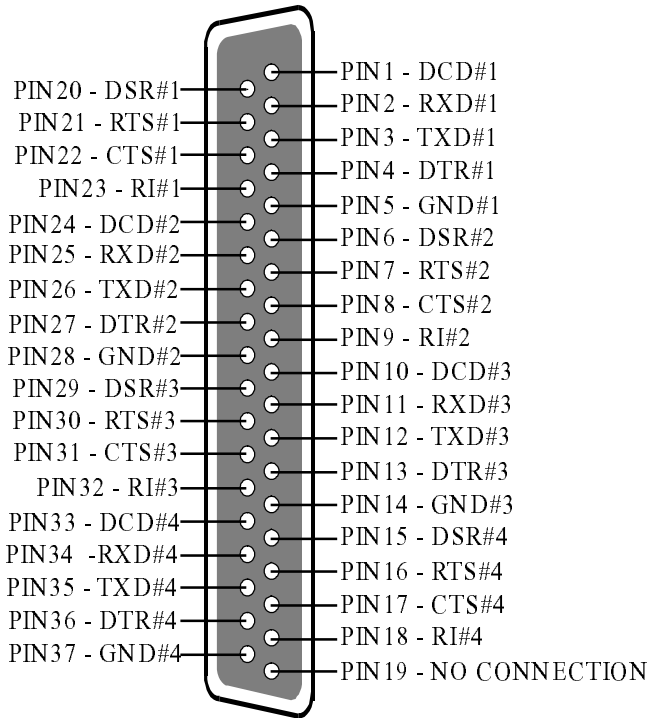

NOTE: On the above diagram the # symbol followed by a number is used to notify a port on the cable. E.g. #4 means port 4, hence PIN36 - DTR#4 is pin 36 of the 37way connector, which corresponds to the DTR function on port 4.

Index

16450 / 16550	6
2500.....	2
adapter	60, 62
Add New Hardware	30, 31
asynchronous	6
baud / baud rate.....	6
BIOS.....	8
bits.....	7, 16, 56
buffer	6
buffered	6
cable	16, 56, 57, 60, 62
connectors	17, 57
Control Panel	30
cross over.....	57, 60, 62
CTS	6, 58
data word length.....	7
DCD	6, 58
default.....	8
driver	30
DSR.....	6, 58
DTR.....	6, 58
FIFO	6
handshake	58
installation	16, 19, 30
jumper.....	6, 14, 16
loop back	56, 60
Maximum Baud Rate	40
menu	30
modem.....	6
PCI Quad RS232 connector pinouts	64
pin outs	56, 57
port / ports	6, 8, 9, 14, 16, 31, 56, 57, 58, 60, 62

Photon 4 Port RS232

Index

receive	58
RI.....	6
RS232	6, 16, 56, 57, 60
RTS	6, 58
RXD	6, 58
serial port.....	6, 8, 9, 14, 16, 31, 56, 58, 60, 62
Serial Port.....	31
Settings	30
setup	8
speed.....	6
stop bits.....	16
TXD.....	6, 58
Uninstalling Serial Solutions PCI for Windows NT.....	55
vector.....	14
Windows.....	2, 4, 8, 19, 30, 31